



Grease System

Section 04-02-01

Komatsu has made every effort to make this manual as accurate as possible based on the information available at the time of publication and printing. Continuous improvement and advancement of product design may cause changes to machines, which may not have been included in this publication. Komatsu reserves the right to make changes and improvements at any time. To ensure the most current information, please contact your service center.

Table of Contents

Scope of This Publication	5
Customer Responsibilities and Warranty Advisories	5
Safety	7
Safety, Warnings, and Cautions	7
Theory of Operation	11
Component Descriptions	13
Grease Reservoir and Pump	13
Grease Reservoir Heater (Optional).....	15
Circuit Descriptions	17
Settings and Adjustments	19
Auto Lube Pump Setup.....	19
Verifying and Setting Auto Lube Cycle Time in LINCS.....	20
Normal Auto Lube Cycle Operation	21
Detailed Grease Alarm Descriptions.....	22
Auto Lube Short Cycle Fault.....	22
Auto Lube Long Cycle Fault	24
Escalating Alarms	25
Checking the Oil Level in the Auto Lube Pump Crankcase.....	26
Safety Preparations	26
Adjust Auto Lube Pump (early production pumps)	31
Safety Preparations	31
Relief Valve Adjustment (early production pumps).....	34
Flow Control Valve Adjustment (Early Production Pumps)	39
Verifying Installation of Solenoid Coil	41
Manual Lube Switches.....	43
Locations	43
Actuation.....	43
Manual Auto Lube Pump Solenoid Bypass	44
Grease Injector Operation, Setup, and Inspection	45
Injector Operation	45
Purge Fitting	47
XL Injectors.....	49
Adjust Grease Injectors	50
Safety Preparations	50
Check Each Grease Injector for Correct Operation.....	55
Vent Valve Operation.....	56
In-Line Filters Maintenance	61
Grease Compatibility.....	62

Filling the Grease Reservoir	64
Safety Preparations	64
Priming the System and Using the Manual Lubrication Functions	66
Auto Lube Pump Setup Check List.....	68
Fluid Specifications	69
Auto Lube Grease Specifications	69
Auto Lube Pump Fluid Specifications	70
Minimum Grease Interval and Volume Requirements for the Spherical Ball Joints	70
Auto Lube Grease Injector Check Sheet Loader	71
Auto Lube Grease Injector Check Sheet Dozer	72

List of Figures

Figure 1.	Self-aligning bushing and pin where level link connects to bellcrank.....	12
Figure 2.	Typical auto lube pump components.....	13
Figure 3.	Typical auto lube grease pump	13
Figure 4.	Auto lube vent valve	14
Figure 5.	Lubrication switch	14
Figure 6.	In line filters	15
Figure 7.	Grease reservoir heater (thermostat called out).....	15
Figure 8.	Typical auto lube circuit.....	17
Figure 9.	Set the auto lube cycle time	20
Figure 10.	Normal grease cycle.....	21
Figure 11.	Auto lube grease restricted.....	22
Figure 12.	Auto lube long cycle	24
Figure 13.	Frame lock in locked position	26
Figure 14.	Battery Isolation Box – Battery isolation switch in OFF position with locks in place	27
Figure 15.	Hydraulic reservoir air valve handle UP	27
Figure 16.	Open air reservoir bleed valves.....	28
Figure 17.	Pressure bleed down valves	28
Figure 18.	Checking oil level without a dipstick.....	29
Figure 19.	Oil dipstick and oil level	29
Figure 20.	Suction gun.....	30
Figure 21.	Battery Isolation Box – Battery isolation switch in OFF position with locks in place	32
Figure 22.	Hydraulic reservoir air valve handle UP	32
Figure 23.	Pressure reducing relief and flow control	34
Figure 24.	Pressure transducer	35
Figure 25.	Installed grease supply line pressure gauge	35
Figure 26.	Pressure adjustment.....	36
Figure 27.	Press the manual lubrication switch (located in the control switches box assemble, front frame or in the cab)	37
Figure 28.	Adjust the stall pressure	37
Figure 29.	Pressure adjustment.....	38
Figure 30.	Flow adjustment	39
Figure 31.	Pressure gauge with correct flow and pressure small flicker at about 350 psi (24 bar).....	40
Figure 32.	Pressure gauge with pump speed too fast wide swing in pressure (cavitation occurs).....	40
Figure 33.	Solenoid coil	41
Figure 34.	Solenoid coil orientation	41
Figure 35.	Solenoid coil middle spade terminal.....	42
Figure 36.	Solenoid coil correct orientation	42
Figure 37.	Solenoid coil incorrect orientation	42
Figure 38.	Lubrication cycle switch.....	43
Figure 39.	SL-1 injector assembly	45
Figure 40.	Injector stages	46
Figure 41.	Injector purge fitting	47
Figure 42.	Injector purge fitting	47
Figure 43.	Grease purge fitting	48
Figure 44.	Grease fitting interference	48
Figure 45.	Dual injectors.....	49

Figure 46.	XL injectors	49
Figure 47.	Battery Isolation Box – Battery isolation switch in OFF position with locks in place	51
Figure 48.	Hydraulic reservoir air valve handle UP	51
Figure 49.	Pressure bleed down valves	52
Figure 50.	Adjust injector	53
Figure 51.	Adjust SL-V XL grease injectors.....	53
Figure 52.	Injector flow	53
Figure 53.	Adjust SL-V injector	54
Figure 54.	Adjust SL-V XL injector.....	54
Figure 55.	Go-No-Go grease injector adjustment gauge.....	55
Figure 56.	Remove plastic cap (SL-1)	55
Figure 57.	Injector in rest position (SL-1).....	55
Figure 58.	Injector position with auto lube grease pump stalled (SL-1)	55
Figure 59.	Install the plastic caps to protect the injectors from contamination	56
Figure 60.	Typical auto lube circuit	56
Figure 61.	Auto lube vent valve	57
Figure 62.	Vent valve in the pressurized and closed position grease supplied to the system	58
Figure 63.	Vent valve in the open position grease is vented back to the bottom of the barrel.....	59
Figure 64.	Vent valve weep hole	59
Figure 65.	Vent valve weep hole	60
Figure 66.	Vent valve orifice	60
Figure 67.	In line filter	61
Figure 68.	In line filter inlet and outlet.....	61
Figure 69.	Filter cleaning	62
Figure 70.	Battery Isolation Box – Battery isolation switch in OFF position with locks in place	65
Figure 71.	Grease reservoir filler fitting.....	66
Figure 72.	Lubrication switch locations.....	67
Figure 73.	Manual auto lube pump solenoid bypass	67
Figure 74.	The minimum grease interval, and volume requirements for the spherical ball joints	70

This Page Intentionally Left Blank

Scope of This Publication

GREASE SYSTEMS contains information about the operation of the automatic lubrication system used to lubricate various components on the machine. System operation and maintenance, and grease specifications are described in this section.

Customer Responsibilities and Warranty Advisories

Komatsu wheel loaders are warranted in accordance with the warranty policy provided with the machine. The recommended operating and maintenance procedures set forth shall be followed to ensure warranty coverage is not jeopardized. Failure to comply with recommended operating and maintenance procedures may void machine warranty.

Any questions or problems relating to warranty policy or administration should be directed to Komatsu Service Center. Include the model and serial number, in-service date of the machine, and hour meter reading. **We especially draw your attention to the following safety advisories.**

This Page Intentionally Left Blank

Safety

This publication contains special instructions that pertain to safety, operation, maintenance, and repair of the machine. Listed below are the signal words and symbols that precede these instructions and their meanings.


DANGER

- The danger label indicates a hazardous situation which, if not avoided, will result in death or serious injury.

WARNING

- The warning label indicates a hazardous situation which, if not avoided, could result in death or serious injury.

CAUTION

- The caution label, used with the safety alert symbol indicates a hazardous situation which, if not avoided, could result in minor or moderate injury (includes the safety alert symbol .

CAUTION

- The caution label (without safety alert symbol) is used to address practices not related to personal injury only equipment damage.

NOTICE

The NOTICE graphic is to indicate areas of importance to the reader that are not related to personal injury or machine damage.

Safety, Warnings, and Cautions

WARNING

MULTIPLE HAZARDS

- Multiple hazards exist including but not limited to fire, explosion, and personal injury, if failing to heed the warnings in the owner's manual regarding misuse, over pressurizing, modifying parts, using incompatible chemicals and fluids, or using worn or damaged parts. Always heed the warnings in the owner's manual. Failure to heed warnings can cause multiple hazards resulting in equipment damage, personal injury or death.

CRUSH HAZARD

- Crush hazards exist if the machine is started or moved while work processes are being performed on the machine. Place bucket flat and level on the ground. Place frame lock in the locked position and lock out the machine's starting capability before performing any work process. Follow all applicable lockout procedures and local rules and regulations for performing work processes. ANYONE performing inspections or service procedures to the machine should be familiar with ALL instructions and procedures contained in the machine's SERVICE MANUAL. Crush hazard

could occur if the machine is started or moves while any type of work process is being conducted on the machine, resulting in serious injury or death.

- Crush hazards exist in machine pivot area and area between the tires. Do not enter these areas unless it is verified that the operator has control over the steering and that personnel locking the frame lock have good communication with the operator. Entering the pivot area and area between the tires while the machine is moving or pivoting (articulating) could cause crush hazards resulting in serious injury or death.
- Crush hazards exist if all personnel are not cleared from the bucket and lift arm area before using the hydraulic hoist and bucket hydraulic pressure bleed down valves to relieve pressure from the hoist and bucket circuit. Assembly must be used only when the engine is NOT running. Before using the Manual Bleed Valve Assembly, refer to “HYDRAULIC AND GREASE SYSTEMS”, “MANUAL BLEED VALVE ASSEMBLY”, in Section 04 of the Service Manual for additional operational and safety information. Operating the manual bleed valve may cause the lift arms and bucket to descend rapidly. All personnel around the bucket and lift arms area shall be removed from the area before operating hydraulic hoist and bucket hydraulic pressure bleed down valves. Using the hydraulic bleed down valves could result in movement of the lift arms and bucket which could cause a crush hazard resulting serious injury or death.

CRUSH, SHOCK, OR OTHER HAZARDS

- Crush, shock, or other hazards exist if stored energy is not removed or isolated prior to working on the machine. Stored energy (hydraulic, electrical, pneumatic, mechanical, etc.) may be present if not isolated or released prior to working on the machine. Do not work on the machine without removing this stored energy (suspended loads, electrical power, air pressure, etc.). Risk of crushing, shock, or other physical injury exists if stored energy is not removed or isolated prior to working on the machine which could result in serious injury or death.

STRUCK-BY OR STRUCK AGAINST HAZARDS

- Struck-by or struck against hazard exists if the injector purge fitting is replaced with the wrong type of fitting. NEVER replace the injector purge fitting (a grease fitting and cap without a sealing ball) with any other type of grease fitting. When the system pressurizes the injector, the sealing ball may be blown out of the injector, becoming a tiny projectile that may cause serious injury. All standard type automotive grease fittings have a seal ball to exclude dirt. They SHALL NOT be used in the grease system of this machine. Failure to use the correct fitting can cause a struck-by hazard resulting in serious injury or death.

SKIN INJECTION HAZARD

- Skin injection hazard exists when around diesel fuel, hydraulic fluid, or grease that is under pressure. Fluids under pressure can penetrate the skin and cause serious personal injury, blindness, or death. Ensure the grease pressure has been bled from the system before removing a transducer to insert a tee. If any fluid is injected into the skin, it must be removed as soon as possible by a doctor familiar with treating this type of injury. Fluid leaks under pressure may not be visible. When searching for leaks, NEVER use your hand; use a piece of metal. Wear work gloves and keep your hand well away from the possible source of leakage. DO NOT tighten or loosen fuel, hydraulic, or grease lines without first relieving the pressure. Wear safety goggles for eye protection and wear all other locally required personal protective equipment (PPE) when working around possibly pressurized liquids. Failure to use proper PPE can cause a skin injection hazard resulting in serious injury or death.
- Skin injection hazard exists when around a pressurized automatic lubrication system. The system generates very high fluid pressure. Extreme caution should be used when operating this equipment as material from dispensing valve or leaks, from loose or ruptured components can inject fluid through the skin and into the body causing serious bodily injury. Adequate personal protection is recommended to prevent splashing of material onto the skin or into the eyes. Failure to wear adequate personal protective equipment (PPE) can cause skin injection hazards resulting in serious injury or death.

CAUTION

WELDING

- Prior to welding on the auto lube reservoir take time to review mine site regulations and take all required welding precautions. It may be necessary to remove all of the grease and clean the grease barrel prior to welding depending on local regulations.

CLEANING MACHINE COMPONENTS

- Avoid washing the grease out of any pivot joint at machine wash-down time. This typically washes the dirty (contaminated) grease back into the joint and allows water (or washing solution) into the joint. The joints should only be cleaned as required for maintenance, repairs, or crack inspections.

COMPONENT BLOCKAGE OR DAMAGE

- Should the automatic lubrication system become inoperable, the machine must be removed from service immediately. Operating the machine without proper operation of the automatic lubrication system will result in serious damage to the ball joints, pins, and bushings.

OVER GREASING

- Over-greasing of the level link and other “high-contamination” location pivot joints is highly recommended. The added grease flushes debris away from the joint.
- Setting the timer at 5 minutes on a new machine and over-greasing for the first 1000 hours is highly recommended. The added grease assures proper break-in of the joints.

REPAIR TECHNICIAN QUALIFICATIONS

- The automatic lubrication system owner’s manual must be reviewed by anyone inspecting or performing maintenance or repair to the automatic lubrication system. The automatic lubrication system should be serviced or repaired by only trained and experienced personnel.

This Page Intentionally Left Blank

Theory of Operation

WARNING

Multiple hazards exist including but not limited to fire, explosion, and personal injury, if failing to heed the warnings in the owner's manual regarding misuse, over pressurizing, modifying parts, using incompatible chemicals and fluids, or using worn or damaged parts. Always heed the warnings in the owner's manual. Failure to heed warnings can cause multiple hazards resulting in equipment damage, personal injury or death.

The auto lube grease system can be set in LINC'S to cycle at 5, 10, or 15 minute intervals. At the beginning of each interval the solenoid (SOL AL) on the Auto Lube Pump is energized which opens and supplies oil to the hydraulic motor part of the Auto Lube Pump. The grease pump supplies grease to the grease supply lines and builds grease pressure to approximately 3250-3800 psi (224-262 bar) at which point the hydraulic motor will stall out and maintain this pressure. After 150 seconds LINC'S turns off the solenoid which stops the Auto Lube Pump. The vent valve then opens and vents grease pressure to the grease reservoir. Typical residual grease pressure in the grease system will be 50-250 psi (3.44 17.2 bar) depending on restrictions in the hoses and vent valve.

When using thicker grease than specified, the extremities of the grease system will receive lower grease pressure than 2500 psi (172 bar) due to flow restrictions in the grease supply lines. If flow restriction is caused by thick grease, the end line injectors will not receive the correct amount of grease and pressure to completely cycle the grease injector in the Discharge stage 2 or in the Reload stage 4 stages (shown in Section 06 of this document).

This occurs in applications where either:

- The grease is thicker than that specified in the machine "Lubrication and Fluid Specification" charts
- The grease is thicker due to 5% moly content
- The grease is thicker due to low temperature extremes

Improper adjustment of the grease pump can cause low hour failures of the Auto Lube Grease Pump. Grease contamination can also cause premature pump failure. Correct Auto Lube Grease Pump setup is detailed in this document.

CAUTION

Failure to properly set up the Auto Lube Pump may cause rapid failure of the pump.

The joint most susceptible to insufficient or incorrect grease damage is typically the self-aligning bushing and pin located where the level link connects to the bellcrank. Premature failures in this area are typically an early warning indication of lubrication issues such as an incorrect amount of grease, auto lube pump that is not pumping, reduced grease flow, operator ignoring alarms, maintenance ignoring alarms, etc.

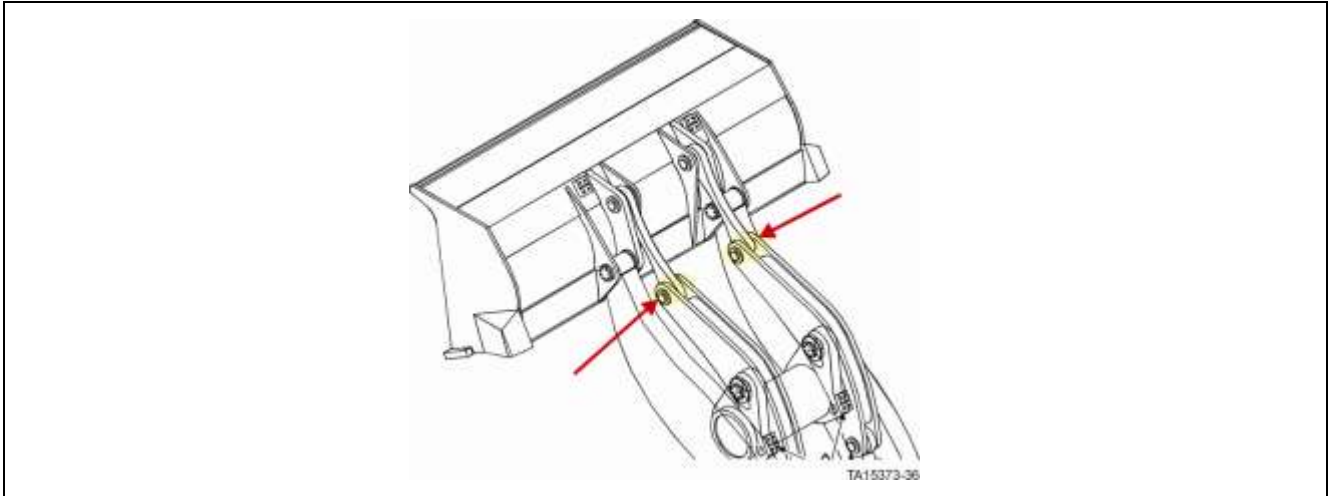


Figure 1. Self-aligning bushing and pin where level link connects to bellcrank

Component Descriptions

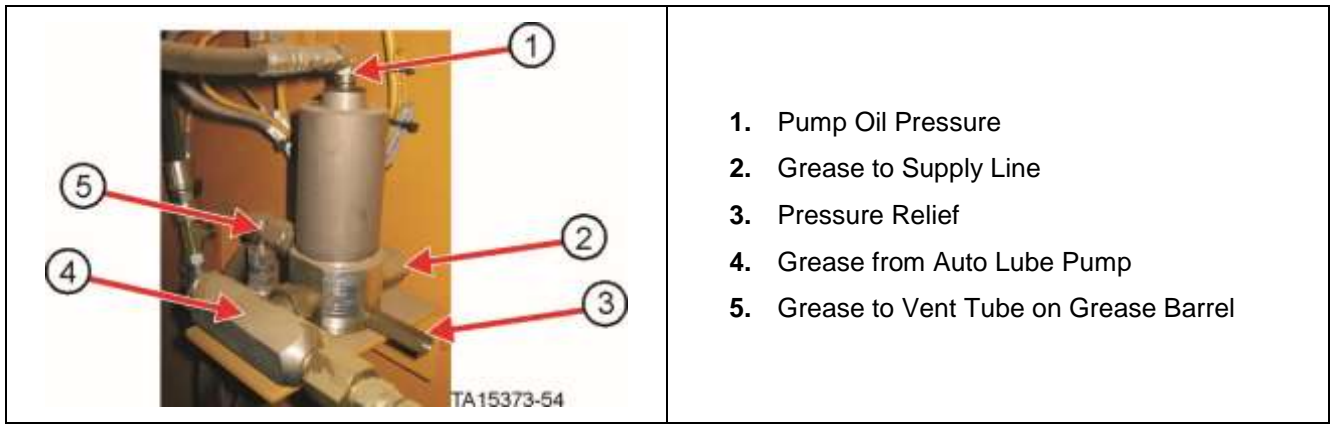
Grease Reservoir and Pump

	<ol style="list-style-type: none"> 1. Vent valve assembly 2. Lubricant Filter 3. Manual Lube Switch* (located in pivot area on some models) 4. ON-OFF solenoid 5. Pump 6. Reservoir 7. Hydraulic Motor 8. Flow control 9. Oil pressure relief 10. Gauge
<p>* Manual lube switch also present on cab overhead switch panel and in Control Switches Box Assembly located on the left side, near rear of the machine.</p>	

Figure 2. Typical auto lube pump components

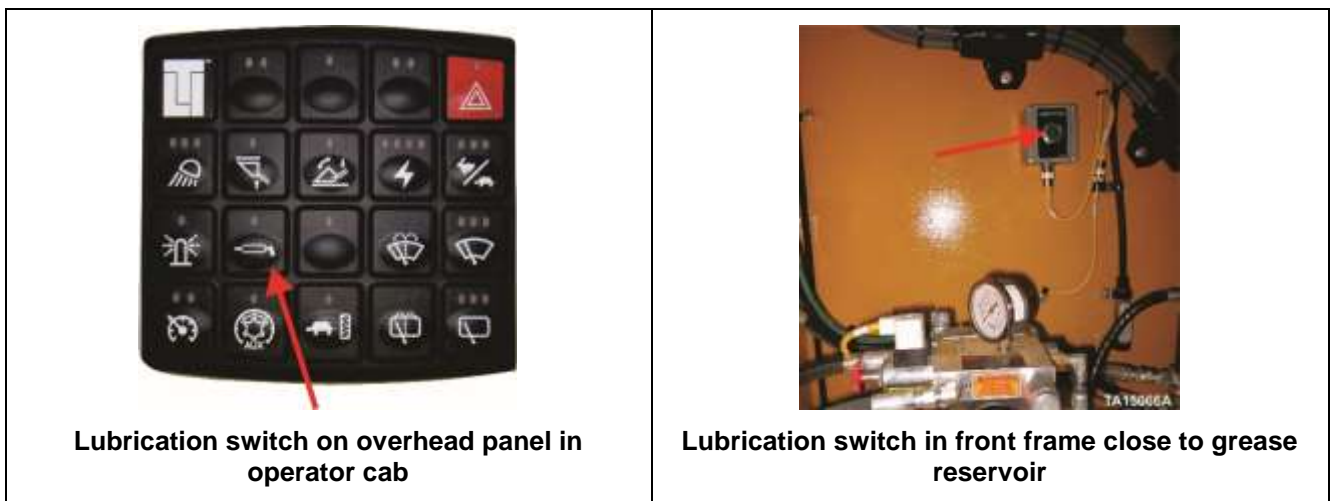


Figure 3. Typical auto lube grease pump



1. Pump Oil Pressure
2. Grease to Supply Line
3. Pressure Relief
4. Grease from Auto Lube Pump
5. Grease to Vent Tube on Grease Barrel

Figure 4. Auto lube vent valve



Lubrication switch on overhead panel in operator cab

Lubrication switch in front frame close to grease reservoir



Lubrication cycle switch inside control switch box (left side, rear of machine)

Figure 5. Lubrication switch

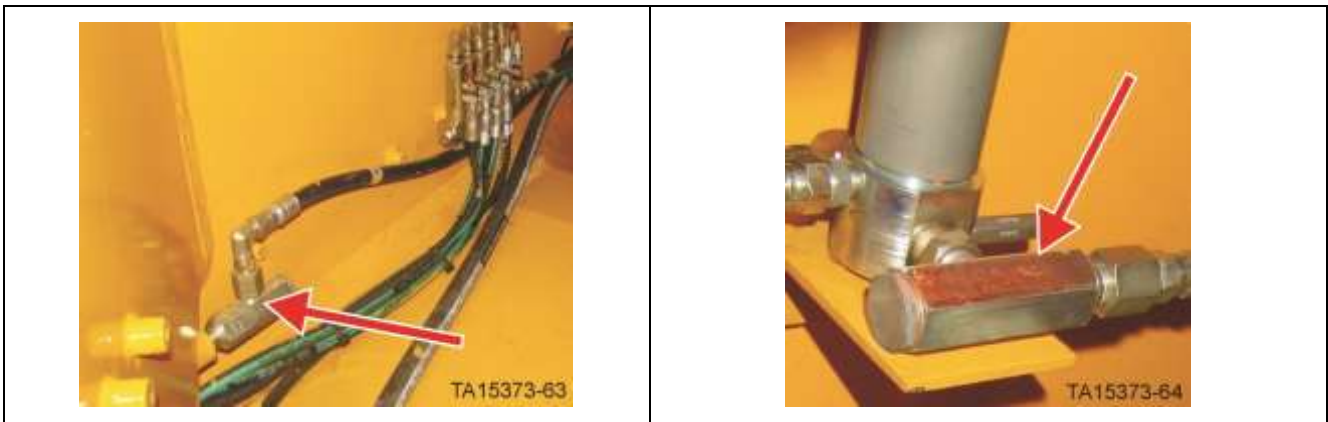


Figure 6. In line filters

Grease Reservoir Heater (Optional)

An optional 240-volt, 1000-watt, thermostatically controlled heater is provided to warm the grease in the reservoir when the machine is parked overnight. The heater operates only on external power. It is controlled by a thermostat control directly attached to the heater. The heater energizes when external power is connected to the component heater receptacle. Refer to "COMPONENT HEATERS" located in Section 06 of the Service Manual. Wiring information for the grease reservoir heater is located on the machine specific Electrical Schematic.

NOTICE

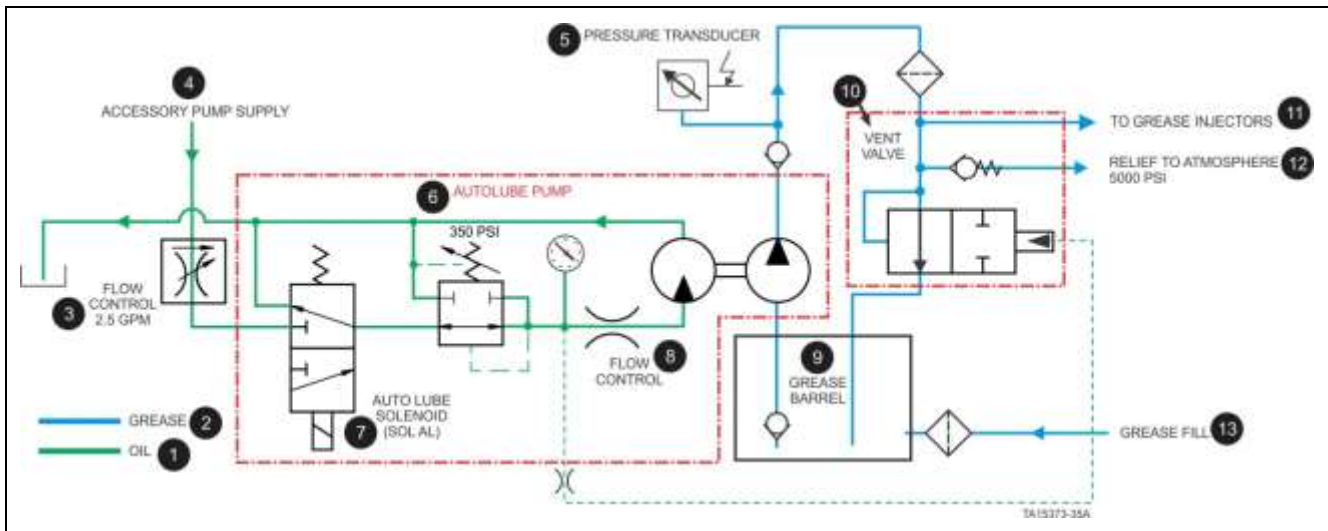
The use of a grease reservoir heater only makes it easier for the grease pump to pump the grease from the reservoir during cold weather. The supply lines and grease injectors are not heated and the use of the correct NLGI grease grade is required to ensure the injectors cycle properly.



Figure 7. Grease reservoir heater (thermostat called out)

This Page Intentionally Left Blank

Circuit Descriptions



- 1. Oil
- 2. Grease
- 3. Flow control 2.5gpm
- 4. Current machines (accessory pump) : supply
- 5. Current machines : pressure transducer
- 6. Autolube pump
- 7. Autolube solenoid (SOL AL)

- 8. Flow amplifier
- 9. Grease barrel
- 10. Vent valve
- 11. To grease injectors
- 12. Relief to atmosphere 4000psi
- 13. Grease fill

Figure 8. Typical auto lube circuit

This Page Intentionally Left Blank

Settings and Adjustments

WARNING

Struck-by hazard exists if standard grease fittings are installed on cylinder eyes or other components for pre-greasing a component and not removed once greasing is complete. Always remove standard grease fittings prior to use on a machine. Standard fittings have a sealing ball that can be expelled from the fitting once the fitting experiences full grease system pressure. They can be replaced with either the lubrication hose or a plug if the port is not used. Failure to remove and replace the fittings can cause struck-by hazards resulting in serious injury or death.

WARNING

Skin injection hazard exists when around diesel fuel, hydraulic fluid, or grease that is under pressure. Fluids under pressure can penetrate the skin and cause serious personal injury, blindness, or death. Ensure the grease pressure has been bled from the system before removing a transducer to insert a tee. If any fluid is injected into the skin, it must be removed as soon as possible by a doctor familiar with treating this type of injury. Fluid leaks under pressure may not be visible. When searching for leaks, NEVER use your hand; use a piece of metal. Wear work gloves and keep your hand well away from the possible source of leakage. DO NOT tighten or loosen fuel, hydraulic, or grease lines without first relieving the pressure. Wear safety goggles for eye protection and wear all other locally required personal protective equipment (PPE) when working around possibly pressurized liquids. Failure to use proper PPE can cause a skin injection hazard resulting in serious injury or death.

WARNING

Skin injection hazard exists when around a pressurized automatic lubrication system. The system generates very high fluid pressure. Extreme caution should be used when operating this equipment as material from dispensing valve or leaks, from loose or ruptured components can inject fluid through the skin and into the body causing serious bodily injury. Adequate personal protection is recommended to prevent splashing of material onto the skin or into the eyes. Failure to wear adequate personal protective equipment (PPE) can cause skin injection hazards resulting in serious injury or death.

Auto Lube Pump Setup

- A. Verify and set Auto Lube cycle time in LINCS to 15 minutes (or less as required in some operations).
- B. Check the oil level in the crankcase of the Auto Lube Grease Pump.
- C. Verify the proper connection and orientation of the Auto Lube Grease Pump solenoid.
- D. Adjust the Auto Lube Grease Pump inlet oil flow and pressure.
 - a. Hydraulic relief valve adjustment
 - Check stall pressure
 - b. Hydraulic flow control setting
 - Check pumping speed

NOTICE

Currently provided grease pump assemblies are non-adjustable.

Verifying and Setting Auto Lube Cycle Time in LINCS



Figure 9. Set the auto lube cycle time

- This only has three possible settings: 5, 10, or 15 minutes.
- Typical setting for Auto Lube Cycle Time in most applications will be 15 minutes.

NOTICE

Maintenance Level (or higher) Security Access is required to set the Auto Lube Cycle Time.

Normal Auto Lube Cycle Operation

The auto lube grease system, pumps grease to the injectors through the grease supply lines. The injectors supply a fixed amount of grease to the joint during each cycle.

The auto lube grease system can be set in LINCS to cycle at 5, 10, or 15 minute intervals.

- At the beginning of each interval, the solenoid (SOL AL) on the Auto Lube Pump is energized which opens and supplies oil to the hydraulic motor of the Auto Lube Pump.
- The grease pump supplies grease to the grease supply lines and builds grease pressure to approximately 3250-3800 psi (224-262 bar) at which point the hydraulic motor stalls out and maintains this pressure. After 150 seconds, LINCS turns off the solenoid, which stops the Auto Lube Pump. The vent valve then opens and vents grease pressure to the grease reservoir.
- Typical residual grease pressure in the grease system will be 50-250 psi (3.44 17.2 bar) depending on restrictions in the hoses and vent valve.

NOTICE

The residual grease pressure must drop below 1000 psi (68.9 bar) with SL-V and SL-V XL injectors for the grease injector to properly cycle.

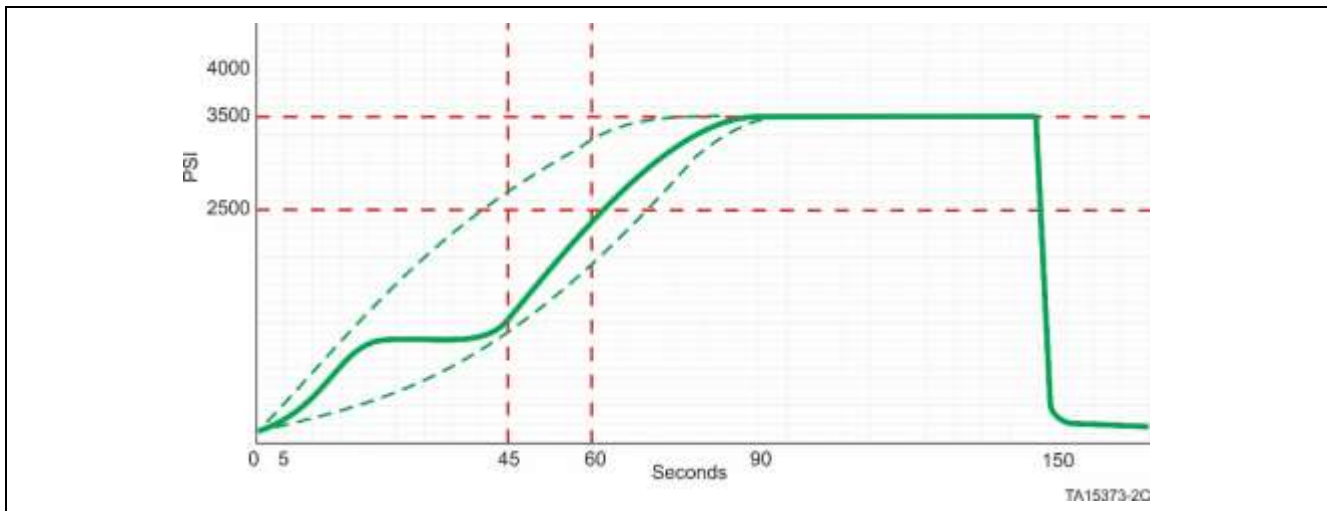


Figure 10. Normal grease cycle

The sequence of events for the automatic lube cycle are:

1. Machine must be in high throttle.
2. LINCS Auto Lube Timer is set by the end user and will be either 5, 10, or 15 minutes. 15 minutes is the default setting.
3. Each time the machine goes to propel enable, the lube cycle timer starts and then continues to repeat at the selected cycle time interval.
4. At the timed interval, LINCS starts a lube cycle.
 - The auto lube solenoid is energized.
 - Pump starts pumping grease into the supply lines.

- The Auto Lube Pump will continue to pump for 150 seconds. The pressure setting of 2500 psi (172 bar) should be reached in approximately 45-75 seconds.
- LINCOS monitors grease pressure during the cycle.
- If the pressure goes to 2500 psi (172 bar) in less than 5 seconds an “Auto Lube Grease Restriction” yellow warning is generated.
- After 5 consecutive Auto Lube Warnings an “Auto Lube Failure” (short cycle) red alarm is generated (this typically indicates a vent valve failure).
- If the grease pressure does not reach 2500 psi (172 bar) within 90 seconds, an “Auto Lube Pressure Failed to Build” yellow warning is generated.
- After 5 consecutive Auto Lube Long Cycle Fault alarms an “Auto Lube Failure” (long cycle) red alarm is generated (this is an indication of an empty grease reservoir, failed pump, open grease supply hose, leaking injector, etc.).

Detailed Grease Alarm Descriptions

There are two (2) grease system yellow warnings that can be generated.

- Auto Lube Short Cycle Warning
- Auto Lube Long Cycle Warning

There are two (2) red alarms that can be generated.

Red alarm for 5 consecutive yellow alarms of the same type.

- Auto Lube Short Cycle Warning
- Auto Lube Long Cycle Warning

Auto Lube Short Cycle Fault

This alarm indicates that the grease pump output pressure achieved 2500 psi (172 bar) in less than 5 seconds.

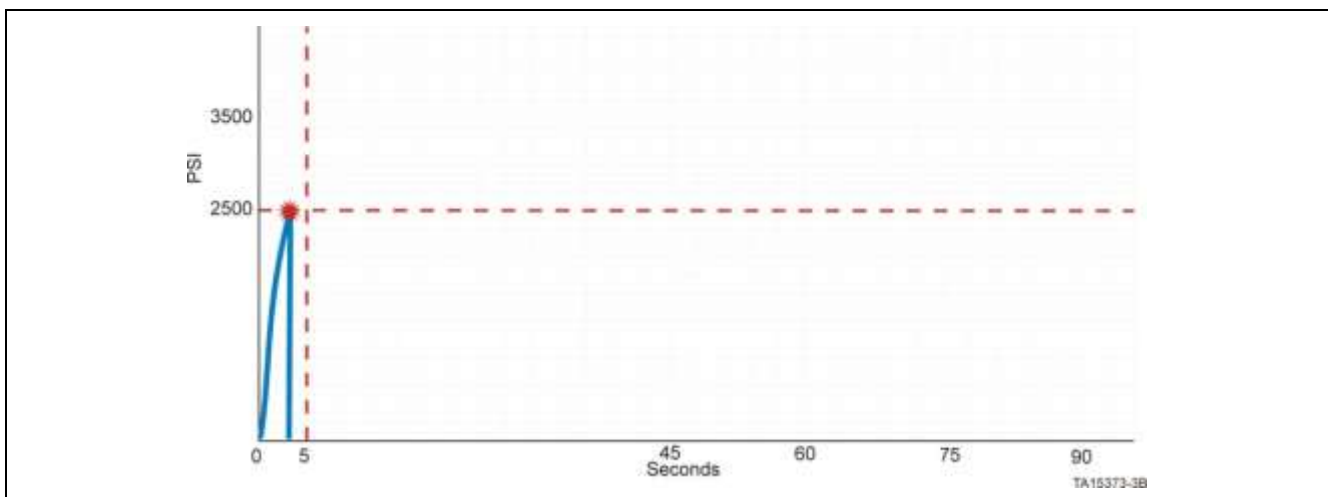


Figure 11. Auto lube grease restricted

This alarm occurs if the vent valve on the grease supply output does not properly vent the grease system pressure at the end of the previous grease cycle. The injectors will not cycle correctly if the grease supply pressure at the injector does not drop to below 600 psi (41.3 bar) with SL-1 injectors or 1000 psi (68.9 bar) with SL-V and SL-V XL injectors after the previous Auto Lube Grease Pump cycle. If residual grease pressure is left in the grease line between the vent valve and the injector bank, from the last grease cycle, when the pump is started the grease pump outlet will immediately pressurize to above 2500 psi (172 bar) which will generate the Auto Lube Short Cycle Fault.

A failed grease pressure transducer can also generate this type of alarm, if the pressure transducer failed in a high-pressure output state.

Auto Lube Long Cycle Fault

This alarm indicates the grease pump output pressure did not achieve 2500 psi (172 bar) within 90 seconds after Auto Lube Grease Pump started.

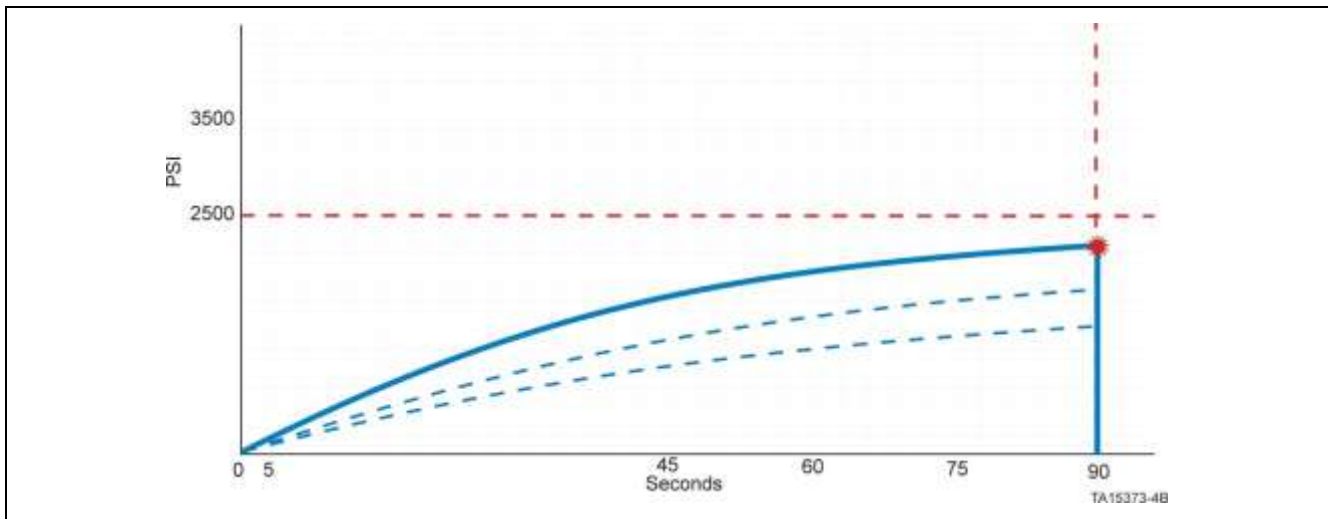


Figure 12. Auto lube long cycle

This alarm could indicate a number of possible failures (this list only shows the most common types of problems it does NOT cover all possibilities).

- No grease in the reservoir
- Broken grease supply hose/s going to the injector banks
- Vent valve failure
- Incorrect pump hydraulic pressure or flow
- Failed grease pressure transducer
- Solenoid valve failure
- Incorrect grease type or high moly content
- Contamination or debris in the grease
- Grease pump failure

Any one of these items could cause the grease pressure not to rise above 2500 psi (172 bar) in the required 90 seconds from the pump turning on.

Escalating Alarms

Historically the joint on the loader that is most susceptible to damage from a grease problem has been the self-aligning bushing between the bellcrank and the level link due to its large rotational angle during each load and dump cycle. This bushing is meant to be greased with two grease injectors set at full flow. If there is no grease, 1.5 to 2 hours of hard work will destroy the self-aligning bushing. Reduced levels of grease over a longer time frame will also cause failures.

To prevent a complete lack of grease from damaging a loader if any of the yellow grease system warning conditions occur for 5 consecutive Auto Lube cycles, then a red “stop machine” alarm is given to alert the operator that the grease warnings have become critical and must be repaired. When the red alarm occurs, the machine engine speed will be reduced to idle and a countdown shut off timer started. The LINCS system has to be rebooted to clear the alarm.

Checking the Oil Level in the Auto Lube Pump Crankcase

Safety Preparations

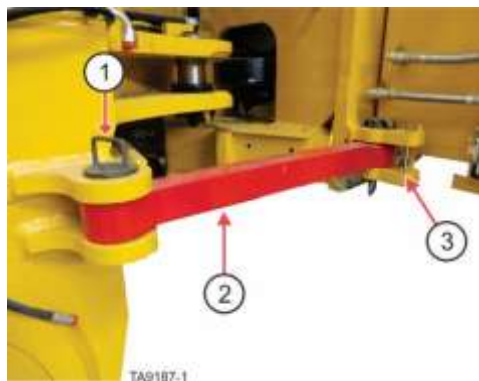
WARNING

Crush hazards exist if the machine is started or moved while work processes are being performed on the machine. Place bucket flat and level on the ground. Place frame lock in the locked position and lock out the machine's starting capability before performing any work process. Follow all applicable lockout procedures and local rules and regulations for performing work processes. ANYONE performing inspections or service procedures to the machine should be familiar with ALL instructions and procedures contained in the machine's SERVICE MANUAL. Crush hazard could occur if the machine is started or moves while any type of work process is being conducted on the machine, resulting in serious injury or death.

- a. Stop the wheel loader on flat level ground.
- b. Set bucket flat and level on the ground.
- c. Move the frame lock to the locked position so that the frame cannot be steered.

WARNING

Crush hazards exist in machine pivot area and area between the tires. Do not enter these areas unless it is verified that the operator has control over the steering and that personnel locking the frame lock have good communication with the operator. Entering the pivot area and area between the tires while the machine is moving or pivoting (articulating) could cause crush hazards resulting in serious injury or death.



- 1) Retaining pin for locked position, 2) Frame lock - shown in locked position,
3) Retaining pin bracket for un-locked position

Figure 13. Frame lock in locked position

- d. Place wheel chocks in front and behind each wheel.
- e. Set the parking brakes.
- f. Shut off the engine.

⚠ WARNING

Crush, shock, or other hazards exist if stored energy is not removed or isolated prior to working on the machine. Stored energy (hydraulic, electrical, pneumatic, mechanical, etc.) may be present if not isolated or released prior to working on the machine. Do not work on the machine without removing this stored energy (suspended loads, electrical power, air pressure, etc.). Risk of crushing, shock, or other physical injury exists if stored energy is not removed or isolated prior to working on the machine which could result in serious injury or death.

- g. Turn the battery and engine isolation switches to the off position and install locks on the battery isolation switch.



Figure 14. Battery Isolation Box – Battery isolation switch in OFF position with locks in place

- h. Release the air from the hydraulic reservoir by using the hydraulic reservoir air valve (ball valve) on top of the reservoir. The supply line from main air system will be blocked and reservoir air will vent out the hose that runs down the outside of the hydraulic reservoir.
- Turn the handle to the up position as shown

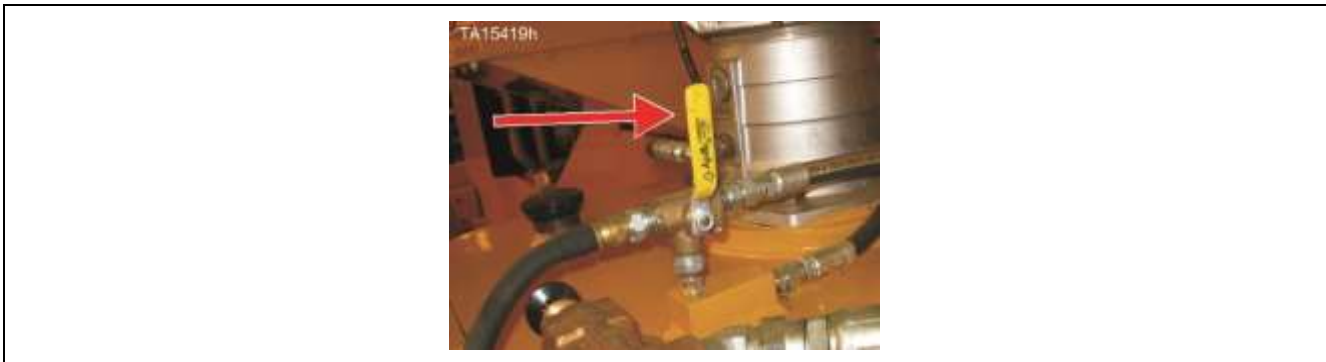


Figure 15. Hydraulic reservoir air valve handle UP

- i. Release the air from the various air storage reservoirs by opening all of the air bleed valves.

Three valves on right side of rear frame under hydraulic reservoir

One valve on right side of front frame near hoist cylinder ball cap



Figure 16. Open air reservoir bleed valves

WARNING

Crush hazards exist if all personnel are not cleared from the bucket and lift arm area before using the hydraulic hoist and bucket hydraulic pressure bleed down valves to relieve pressure from the hoist and bucket circuit. Assembly must be used only when the engine is NOT running. Before using the Manual Bleed Valve Assembly, refer to “HYDRAULIC AND GREASE SYSTEMS”, “MANUAL BLEED VALVE ASSEMBLY”, in Section 04 of the Service Manual for additional operational and safety information. Operating the manual bleed valve may cause the lift arms and bucket to descend rapidly. All personnel around the bucket and lift arms area shall be removed from the area before operating hydraulic hoist and bucket hydraulic pressure bleed down valves. Using the hydraulic bleed down valves could result in movement of the lift arms and bucket which could cause a crush hazard resulting serious injury or death.

- j. Use the hydraulic pressure bleed down valves located in the front frame underneath the Husco valves to bleed any stored pressure in the hoist and bucket cylinders.
- k. Turn each valve slowly counterclockwise as shown below and allow the pressure to bleed down.
 - Open the valve completely and leave it open during this procedure.

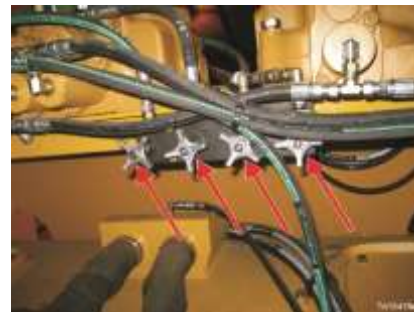


Figure 17. Pressure bleed down valves

Early Production Models: To check the oil level in the pump housing of the original model without a dipstick, remove the oil plug located in the side of the pump housing.

- The oil in the pump housing should be even with the bottom of the plug hole.
- If the level is not full, check for leaks and repair as necessary.
- Oil can be added through the Fill Plug hole.



Figure 18. Checking oil level without a dipstick

Current Production Models: To check the oil level the dipstick can be removed and inspected for proper oil level.

- Oil level should be at the dot on the dipstick (middle of crankshaft).
- If the level is not full, check for leaks and repair as necessary.
- Oil can be added through the Dipstick hole.

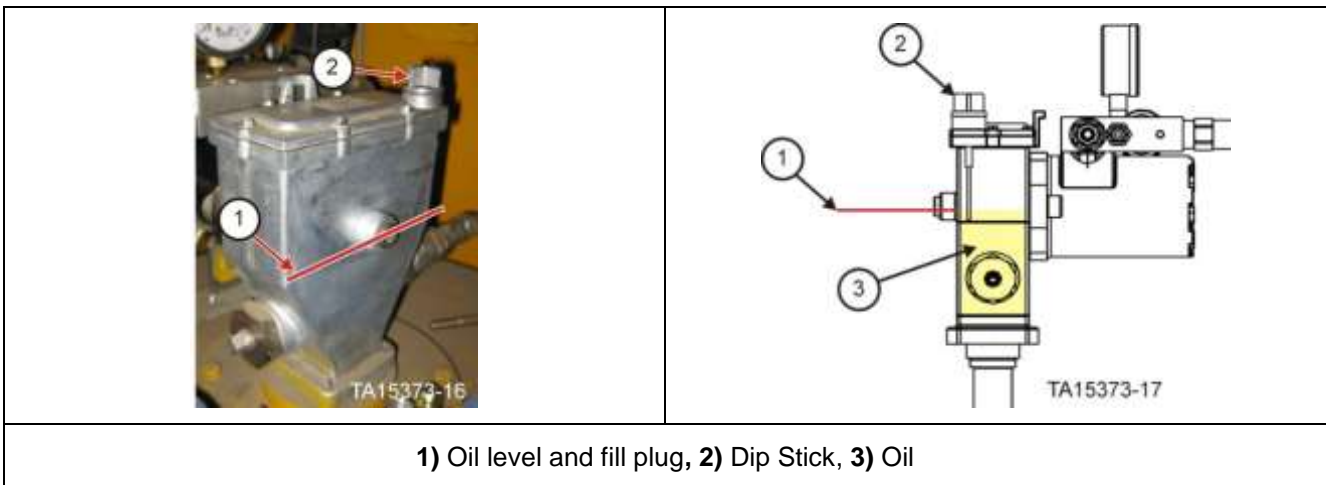


Figure 19. Oil dipstick and oil level

Crankcase Oil Service Interval Recommendations

- Check the oil level after every 1000 hours of machine (loader or dozer) operation.
- Change the oil after every 2000 hours of machine (loader or dozer) operation.
- Capacity: 15 oz. (444 ml.)

Ambient Temperature	Oil Type
-40°F (-40°C) and 150°F (66°C)	10W-30 Engine oil
-70°F (-57°C) to 50°F (10°C)	Mobil Aero HFA

The pump gearbox may not have a drain port. The oil can be removed by:

- Removing the pump and turning it over
- Use a suction tool such as the Lincoln 615 suction gun shown below



Figure 20. Suction gun

- I. Follow all lockout tag out rules, local rules, and local regulations to return the machine back to service.

Adjust Auto Lube Pump (early production pumps)

Safety Preparations


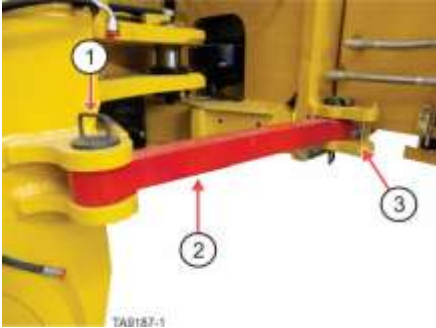
WARNING

Crush hazards exist if the machine is started or moved while work processes are being performed on the machine. Place bucket flat and level on the ground. Place frame lock in the locked position and lock out the machine's starting capability before performing any work process. Follow all applicable lockout procedures and local rules and regulations for performing work processes. ANYONE performing inspections or service procedures to the machine should be familiar with ALL instructions and procedures contained in the machine's SERVICE MANUAL. Crush hazard could occur if the machine is started or moves while any type of work process is being conducted on the machine, resulting in serious injury or death.

- a. Stop the wheel loader on flat level ground.
- b. Set bucket flat and level on the ground.
- c. Move the frame lock to the locked position so that the frame cannot be steered.

WARNING

Crush hazards exist in machine pivot area and area between the tires. Do not enter these areas unless it is verified that the operator has control over the steering and that personnel locking the frame lock have good communication with the operator. Entering the pivot area and area between the tires while the machine is moving or pivoting (articulating) could cause crush hazards resulting in serious injury or death.

	
<p>Gen 1 Frame lock in locked position</p>	<p>Gen 2 Frame lock in locked position</p>
<p>1) Retaining pin for locked position, 2) Frame lock - shown in locked position, 3) Retaining pin bracket for un-locked position</p>	

Frame lock in locked position

- d. Place wheel chocks in front and behind each wheel.
- e. Set the parking brakes.
- f. Shut off the engine.

⚠ WARNING

Crush, shock, or other hazards exist if stored energy is not removed or isolated prior to working on the machine. Stored energy (hydraulic, electrical, pneumatic, mechanical, etc.) may be present if not isolated or released prior to working on the machine. Do not work on the machine without removing this stored energy (suspended loads, electrical power, air pressure, etc.). Risk of crushing, shock, or other physical injury exists if stored energy is not removed or isolated prior to working on the machine which could result in serious injury or death.

- g. Turn the battery and engine isolation switches to the off position and install locks on the battery isolation switch.



Figure 21. Battery Isolation Box – Battery isolation switch in OFF position with locks in place

- h. Release the air from the hydraulic reservoir by using the hydraulic reservoir air valve (ball valve) on top of the reservoir. The supply line from main air system will be blocked and reservoir air will vent out the hose that runs down the outside of the hydraulic reservoir.
- Turn the handle to the up position as shown

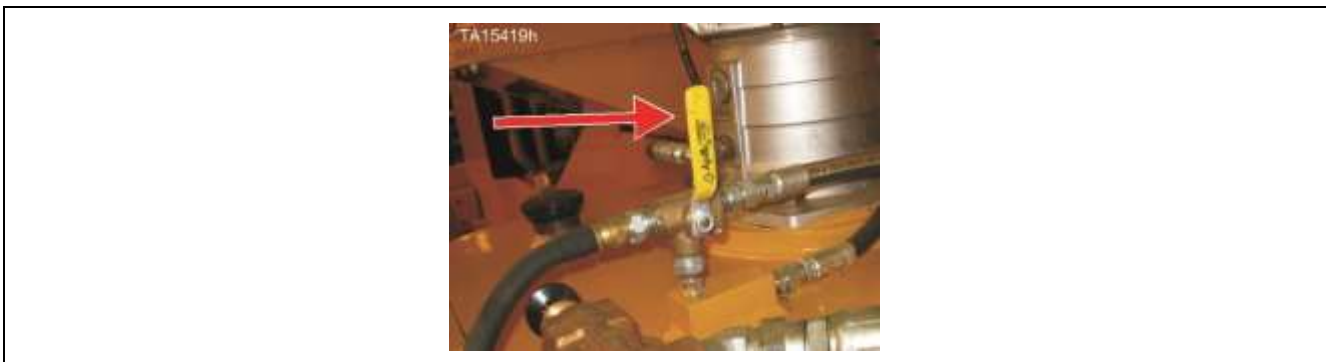


Figure 22. Hydraulic reservoir air valve handle UP

- i. Release the air from the various air storage reservoirs by opening all of the air bleed valves.
- Some machines do not have a remote drain valve for the KLENZ reservoir. They have only a manual valve on the bottom of the reservoir that must be manually released.

Three valves on right side of rear frame under hydraulic reservoir

One valve on right side of front frame near hoist cylinder ball cap



Open air reservoir bleed valves

WARNING

Crush hazards exist if all personnel are not cleared from the bucket and lift arm area before using the hydraulic hoist and bucket hydraulic pressure bleed down valves to relieve pressure from the hoist and bucket circuit. Assembly must be used only when the engine is NOT running. Before using the Manual Bleed Valve Assembly, refer to “HYDRAULIC AND GREASE SYSTEMS”, “MANUAL BLEED VALVE ASSEMBLY”, in Section 04 of the Service Manual for additional operational and safety information. Operating the manual bleed valve may cause the lift arms and bucket to descend rapidly. All personnel around the bucket and lift arms area shall be removed from the area before operating hydraulic hoist and bucket hydraulic pressure bleed down valves. Using the hydraulic bleed down valves could result in movement of the lift arms and bucket which could cause a crush hazard resulting serious injury or death.

NOTICE

Currently provided pumps are non-adjustable for both flow and pressure.

CAUTION

An old pump that is already close to failing may fail quickly after adjustment.

A pump that does not have the pressure and flow properly adjusted may fail quickly.

The auto lube pump has two adjustments:

- j. Oil Pressure Control: pressure reducing relief setting for setting the maximum hydraulic pressure on the motor when stalled.
- k. Oil Flow Control: Flow control for setting the pump speed.



- 1) Pressure reducing relief (non adjusting shown)
 2) Flow control (non-adjusting shown)

Figure 23. Pressure reducing relief and flow control

Required Tools

- Hex key wrench
- Combination wrench
- Gauge 0-5000 psi (0 345 bar) and high pressure tee.

Relief Valve Adjustment (early production pumps)

If the Auto Lube Pump has a built in adjustable pressure regulator, the regulator must be adjusted for proper operating pressure.

⚠ WARNING

Skin injection hazard exists when around diesel fuel, hydraulic fluid, or grease that is under pressure. Fluids under pressure can penetrate the skin and cause serious personal injury, blindness, or death. Ensure the grease pressure has been bled from the system before removing a transducer to insert a tee. If any fluid is injected into the skin, it must be removed as soon as possible by a doctor familiar with treating this type of injury. Fluid leaks under pressure may not be visible. When searching for leaks, NEVER use your hand; use a piece of metal. Wear work gloves and keep your hand well away from the possible source of leakage. DO NOT tighten or loosen fuel, hydraulic, or grease lines without first relieving the pressure. Wear safety goggles for eye protection and wear all other locally required personal protective equipment (PPE) when working around possibly pressurized liquids. Failure to use proper PPE can cause a skin injection hazard resulting in serious injury or death.

- a. Disconnect the pressure transducer or pressure switch.



Figure 24. Pressure transducer

NOTICE

Part of the adjustment is to cause the Auto Lube Pump to stall out. If the adjustment takes more than 90 seconds, it will be possible to get a Long Cycle Alarm message on the LINC'S monitor in the cab.

- b. Install tee and pressure gauge (0-5000 psi [0-345 bar]) in the grease supply line next to the pressure transducer.



Pressure gauge (5,000 psi [345 bar])

Figure 25. Installed grease supply line pressure gauge

- c. Loosen the jam nut on the pressure reducing relief and turn the adjustment screw three turns counterclockwise (CCW). This should ensure minimal pressure when the Auto Lube Pump starts.

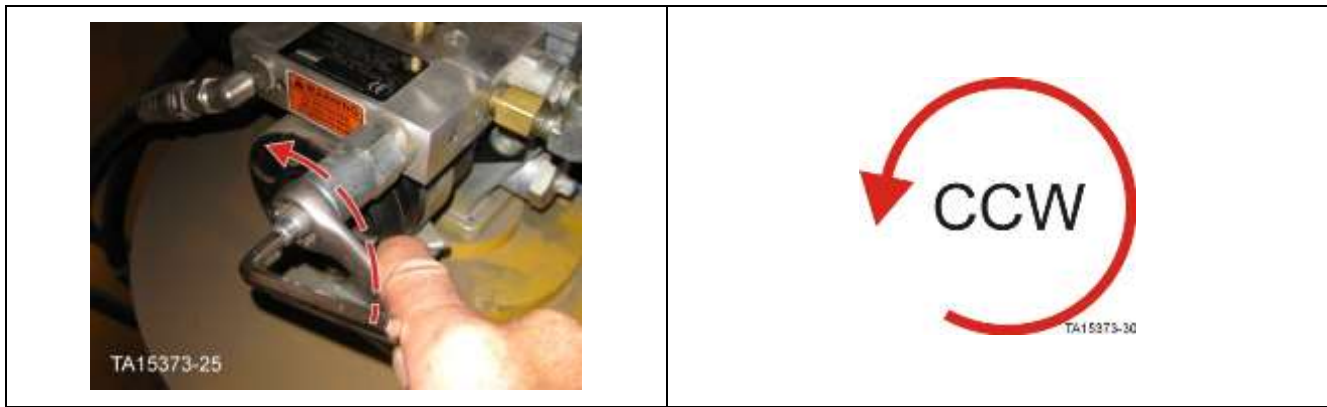


Figure 26. Pressure adjustment

- d. Boot up LINCS computer system and follow all local rules to start the engine.

NOTICE

The automatic lubrication system is hydraulically powered. The engine must be running to make adjustments. LINCS software will turn on the solenoid and Auto Lube Pump for 90 seconds.

- e. Run the machine until the hydraulic oil is warmed up to at least 140°F (60°C).
- f. Check the auxiliary pump pressure setting and verify that it is correct for your machine. (See the Specifications sheet located in Section 01 of the Service Manual or hydraulic schematic for your machine to determine the settings.)
- g. Check that the flow control valve in the oil supply line is functioning correctly.
- h. Put machine at high engine RPM and with air conditioner on cooling mode and the refrigerant compressor running.
- i. Activate the manual lube switch.





Figure 27. Press the manual lubrication switch (located in the control switches box assemble, front frame or in the cab)

- j. Watch the grease pressure gauge. In approximately 45-60 seconds, the pump should stall with grease output pressure at 3250-3800 psi (224 262 bar). (This will typically be approximately 350 psi (24 bar) oil pressure as indicated on the oil pressure gauge on the Auto Lube Pump manifold)

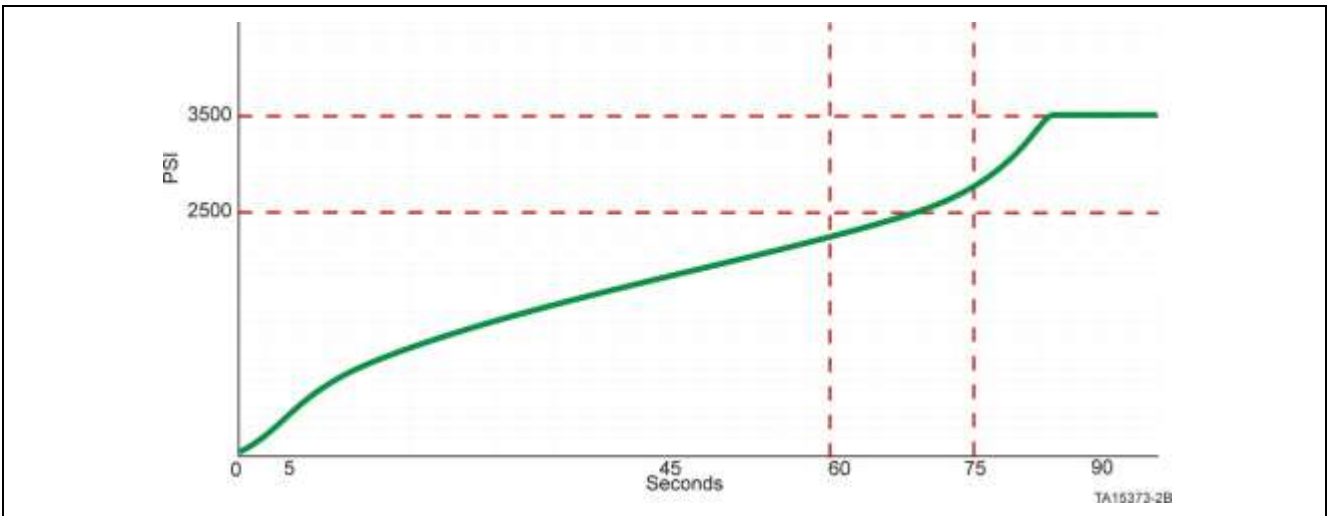


Figure 28. Adjust the stall pressure

- k. Adjust the pressure reducing relief to get the correct grease stall pressure.
 - a. To increase the grease pressure, turn the adjustment screw, clockwise (CW).
 - b. To decrease the grease pressure, turn the adjustment screw, counterclockwise (CCW).



Figure 29. Pressure adjustment

- l. Monitor the oil pressure on the gauge on the Auto Lube Pump manifold.

CAUTION

Do not adjust the pump pressure greater than 350 psi (24 bar), or pump damage may occur. If the pump is cycling very rapidly and grease output pressure can't be achieved, the flow control must be adjusted first.

- m. Once 3250-3800 psi (224-262 bar) grease pressure is achieved, re-tighten the jam nut on the pressure relief.
- n. Recheck the stall pressure setting by actuating the lubrication cycle switch in the pivot area.
- o. Remove the pressure gauge in the grease output line. (This gauge can be left for future adjustment).
- p. Reconnect the pressure transducer or pressure switch.
- q. In LINCS verify that the Auto Lube Pump is energized for 150 seconds and the grease pressure rises above 2500 psi (172 bar).

Flow Control Valve Adjustment (Early Production Pumps)

If the Auto Lube Pump has a built in adjustable flow regulator, the regulator must be adjusted for proper flow rate to ensure the pump does not pump too slow or too fast.

CAUTION

If the hydraulic flow is too high, for most grease types, the pump will cycle faster than the grease can flow into the suction tube of the pump. This can cause rapid failure of the pump.

NOTICE

There should be a 2.5 gpm (9.46 lpm) (LET PN 424-4881), flow control in line with the oil supply to the grease pump. This provides protection from an extreme over speed.

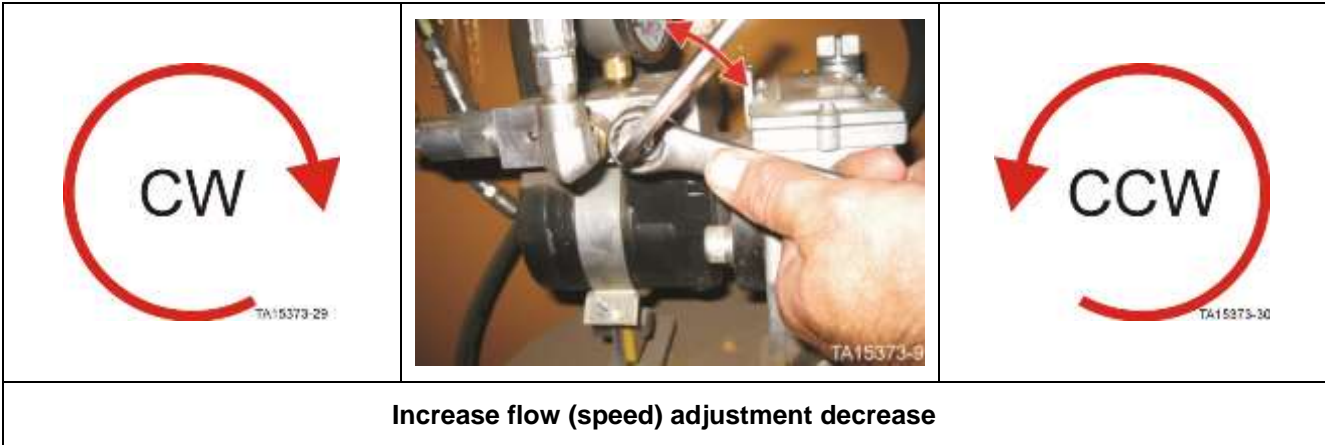


Figure 30. Flow adjustment

- a. Loosen the jam nut on the flow control valve.
- b. Turn the adjustment screw clockwise (CW) until it stops.

- c. Turn the adjustment screw counterclockwise (CCW) 1/4 turn. This should give an approximate flow that is correct and within tolerance.
1. The grease pump should be set to cycle at about 1.5 to 2 strokes per second at the start of the grease cycle. As grease output pressure increases, the pump will cycle slower and slower until the pump stalls.
 2. Check the oil pressure gauge on the Auto Lube Pump manifold.
 - If the flow rate is correct, the oil pressure gauge will be at about 325 to 350 psi (24 bar) and the needle will have a small 10-20 psi (0.69 1.38 bar) flicker.



Figure 31. Pressure gauge with correct flow and pressure small flicker at about 350 psi (24 bar)

- If the flow rate is too fast, the oil pressure gauge needle will have a wide swing.



Figure 32. Pressure gauge with pump speed too fast wide swing in pressure (cavitation occurs)

3. Adjust the flow rate so that the grease pressure builds to 2500 psi (172 bar) in approximately 60 - 75 seconds.
 - If the cycle time is set too fast, grease pump cavitation can occur and damage the pump. Cavitation is caused by thick grease not being drawn into the pump suction port as fast as the pump requires. This causes damage to the seals in the pump.
 - If the cycle time is set too slow then the pressure may not build to the correct pressure fast enough and can cause a long cycle alarm.
 4. Grease temperature, viscosity, molybdenum content, and NLGI grade can all affect cavitation.
- d. Turn the adjustment screw clockwise to slow the pump speed
- e. Turn the adjustment screw counterclockwise to increase the pump speed.

If the pressure and flow rate cannot be set properly, the following items need to be inspected, repaired, and or replaced. (Refer to the troubleshooting section in the Lincoln Auto Lube pump manufacturer literature)

<ul style="list-style-type: none"> • Accessory pump pressure • 2.5 gpm (9.46 lpm) Flow Control • Out of Grease • Grease Pump Relief valve • Broken grease line hose • Contamination in the suction tube of the grease pump (lower check valve) • Grease pump solenoid valve 	<ul style="list-style-type: none"> • Cold hydraulic oil must be warmed up • Bad Grease Pump • Wrong type of Grease for climate • Grease Pump flow control • Grease pump vent valve malfunction • Faulty electrical switch
--	---

Verifying Installation of Solenoid Coil

The solenoid coil actuates the hydraulic valve to control the supply oil to the Auto Lube Pump control valve.

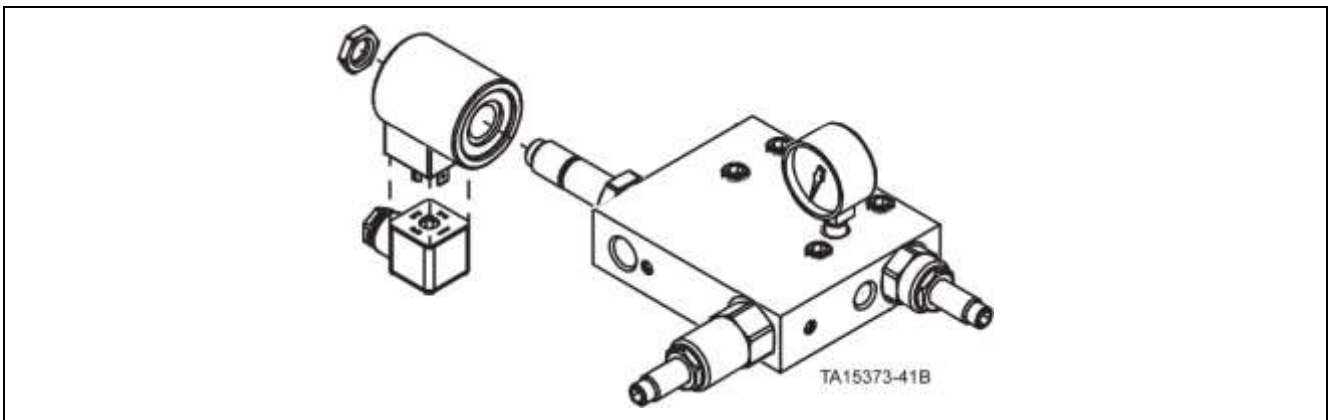


Figure 33. Solenoid coil

The coil must be oriented as shown in the figure to properly engage the solenoid when energized.

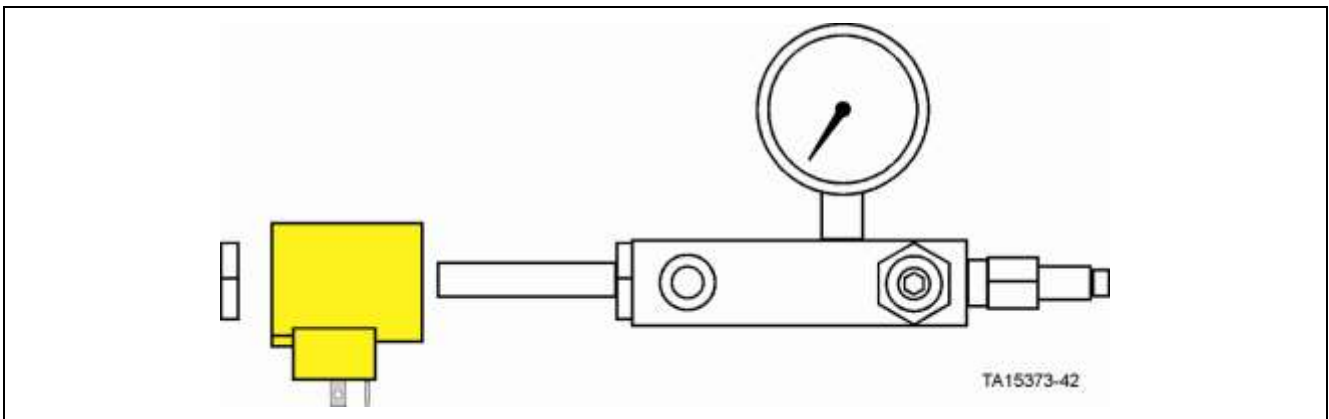


Figure 34. Solenoid coil orientation

There are three flat spade type terminals on the coil. The terminal in the middle should be oriented toward the block.

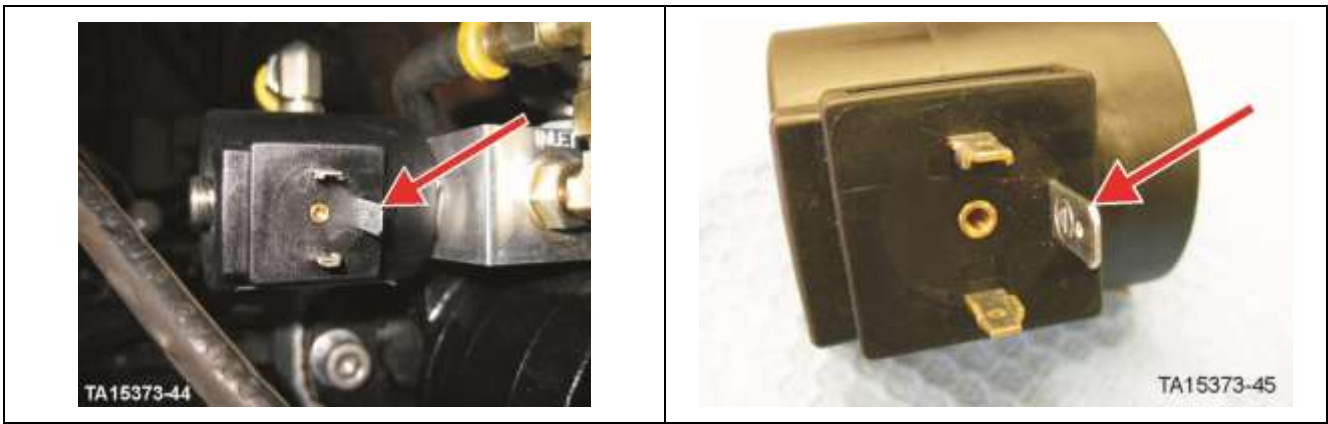


Figure 35. Solenoid coil middle spade terminal

The end of the coil that mounts against the block has a metal washer with white plastic in middle.

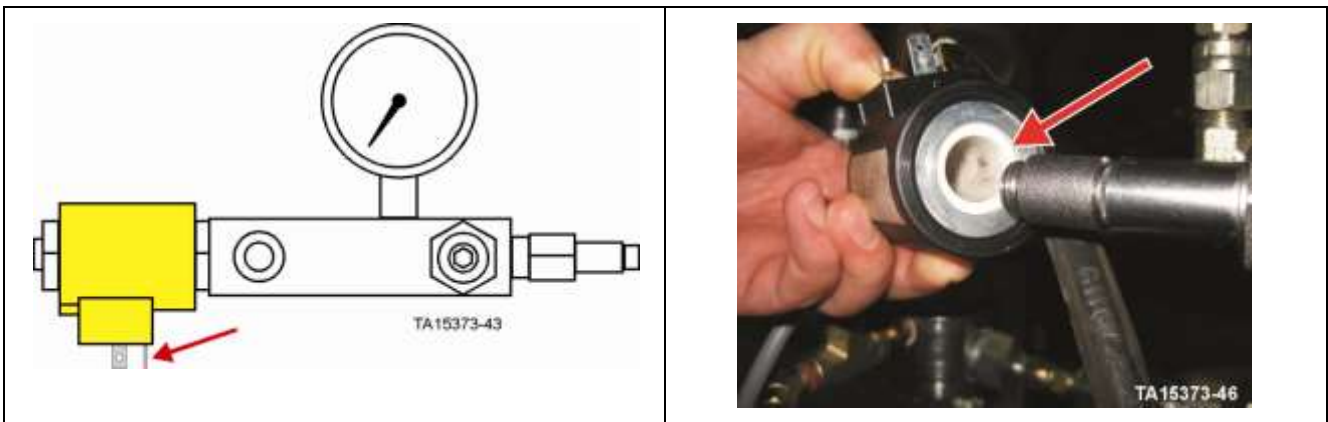


Figure 36. Solenoid coil correct orientation

The end of the coil with the solid metal washer mounts against the retainer nut NOT against the block.

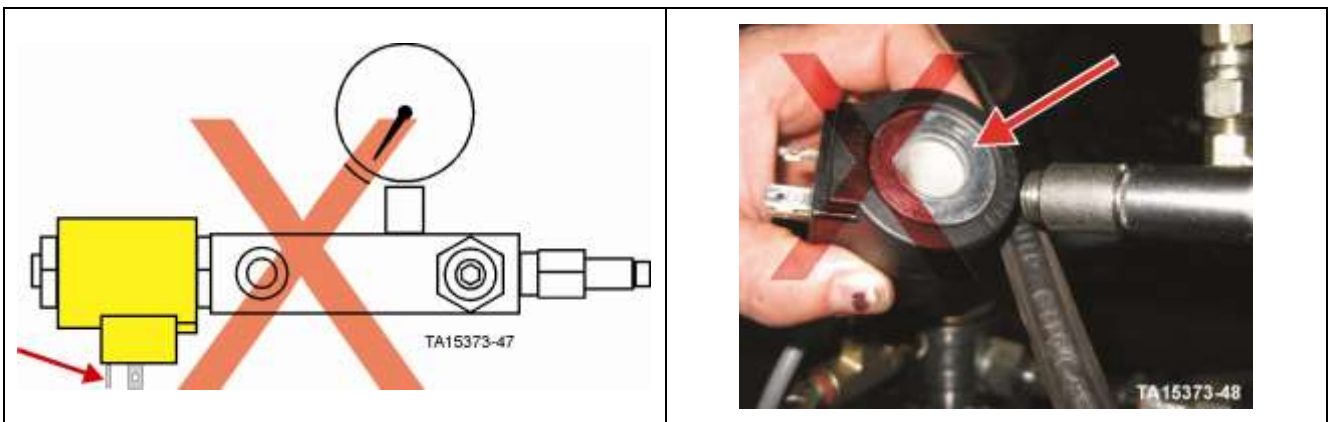


Figure 37. Solenoid coil incorrect orientation

Manual Lube Switches

Manual lube switches are located on the machine for direct input from either maintenance personnel or the operator. The Lube Switches are two-position momentary switches that start the automatic lubrication pump. The engine must be running for the Lube Switches to operate.

Locations

- On the Overhead Switch Panel
- In the Control Switch Box mounted at the left rear of the machine
- Inside the front frame, above the auto lube pump

Actuation

Low Throttle with drive disabled

Pressing the Manual Lube Switch activates the lubrication pump. The LED illuminates. Releasing the switch turns the lubrication pump OFF.

- LED goes OFF.

High Throttle with drive enabled

Pressing the Manual Lube Switch activates the lubrication pump. The pump cycles through the set cycle time.

- The LED illuminates until the pump turns OFF.

Should there be a problem with the lubrication system, either a Yellow Warning Light or a Red Alarm Light, and an audible alarm comes on and a message appears on the computer screen.



Lubrication switch on overhead panel in operator cab



Lubrication switch in front frame close to grease reservoir



Lubrication cycle switch inside control switch box located on left rear of machine

Figure 38. Lubrication cycle switch

Manual Auto Lube Pump Solenoid Bypass

A manual solenoid bypass is provided on the auto lube pump assembly. While the engine is running, the solenoid can be used to place the pump in either bypass or normal operation. Refer to text “Priming the System and using the Manual Lubrication Function”, in this document, for more information.

Grease Injector Operation, Setup, and Inspection

Injector Operation

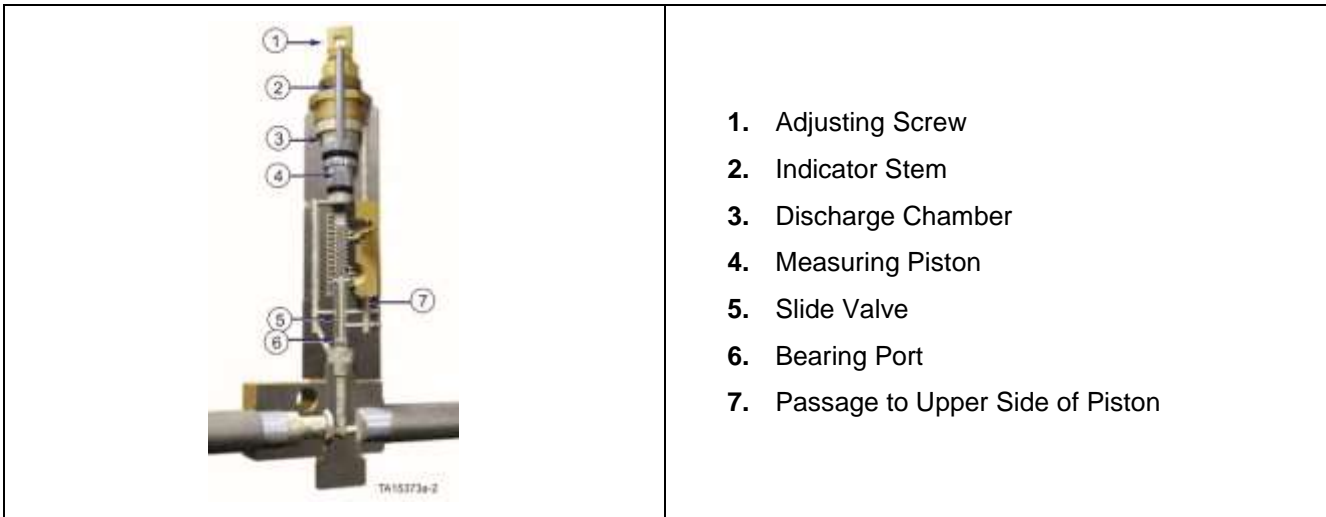


Figure 39. SL-1 injector assembly

<p>Stage 1</p>	<ul style="list-style-type: none"> • The discharge chamber is filled with lubricant from the previous cycle. • Under pressure of incoming lubricant, lubricant is directed to both sides of the measuring piston through the slide valve. • The port to the bearing is closed in this position which prevents the measuring piston from moving. • The indicator stem will be at its' innermost position, having pulled away from the stop in the adjusting screw.
<p>Stage 2</p>	<ul style="list-style-type: none"> • Pressure has built up and has moved the slide valve in position shown. This closes the flow passage to the upper side of piston (large diameter) while simultaneously opening the port to allow lubricant to flow out of the injector to the bearing. The grease pump is turned on and pressurizes the supply lines. • Pressure from the supply line continues to apply pressure to the lower portion of the measuring piston, which causes a pressure difference across the measuring piston thus allowing it to move upward.
<p>Stage 3</p>	<ul style="list-style-type: none"> • Movement of the measuring piston is caused by the pressure on the lower side of the measuring piston dispensing lubricant out to the bearing. • The indicator stem will move up against the stop in the adjusting screw when all lubricant has been delivered to the bearing.

Stage 4	<ul style="list-style-type: none">• As the pressure in the supply line is vented down to 1,000 psi the slide valve moves back to its rest position.• Flow of lubricant to the bearing is closed and simultaneously allows lubricant to flow to the upper (large diameter) of the piston.• The displacement of fluid on the lower side of the measuring chamber is also allowed by the slide valve to flow to the upper side of the piston.• The injector is recharged by the residual pressure in the supply line to the upper portion of the measuring chamber.
---------	---

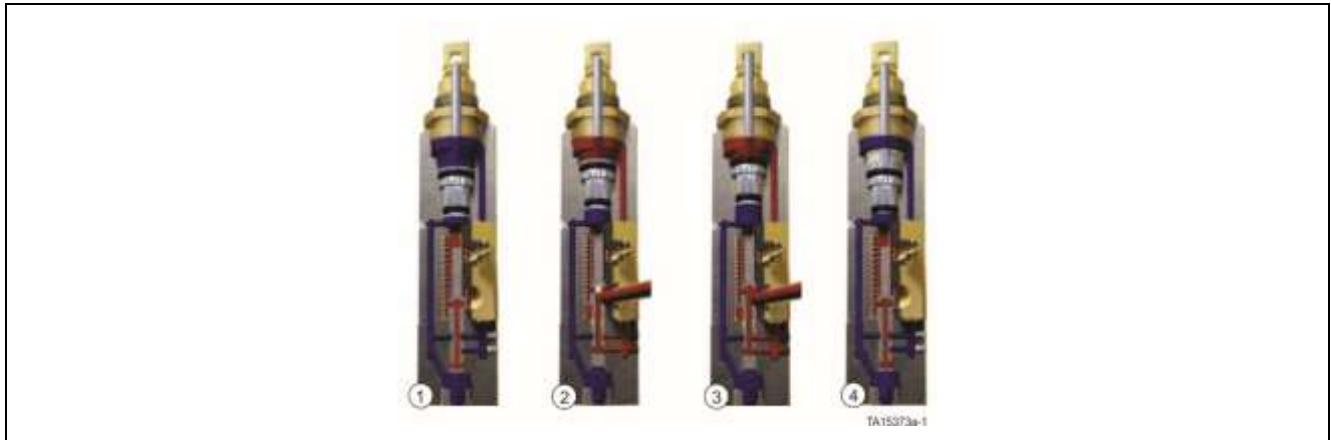


Figure 40. Injector stages

Purge Fitting

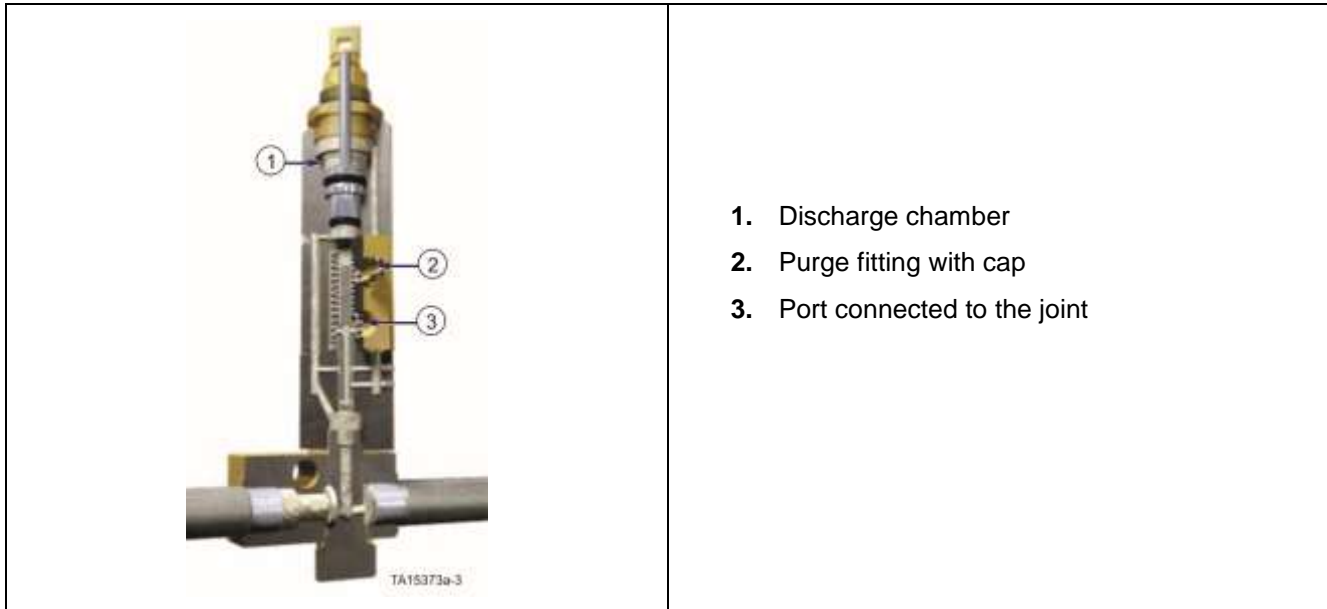


Figure 41. Injector purge fitting

The discharge chamber on each grease injector is provided with two ports.

- The ports are interchangeable.
- One of the ports has a fitting installed and is connected by hose to the joint being lubricated.
- The other port has a purge fitting that appears to be a grease fitting with a cap. When the cap is removed, a grease gun can be connected. Inputting grease at this fitting allows the line to the joint to be filled with grease and purged of air.

CAUTION

When any grease hose between an injector and a lube point is replaced, the new hose must be filled with the proper grease prior to machine operation. Failure to fill the hose prior to operation can lead to component failure, as it will likely take many cycles of the system to fill the hose with grease. This can be done by:

Filling the hose prior to installation.

Fill the hose with grease by pumping grease from an external pump into the purge fitting on the associated grease injector.

Any time a new hose is installed the purge fitting should be used to fill the hose with grease.

This is a special fitting that does not have a sealing ball.

DO NOT use a standard grease fitting in this location.



Figure 42. Injector purge fitting

⚠ WARNING

Struck-by or struck against hazard exists if the injector purge fitting is replaced with the wrong type of fitting. **NEVER** replace the injector purge fitting (a grease fitting and cap without a sealing ball) with any other type of grease fitting. When the system pressurizes the injector, the sealing ball may be blown out of the injector, becoming a tiny projectile that may cause serious injury. All standard type automotive grease fittings have a seal ball to exclude dirt. They **SHALL NOT** be used in the grease system of this machine. Failure to use the correct fitting can cause a struck-by hazard resulting in serious injury or death.

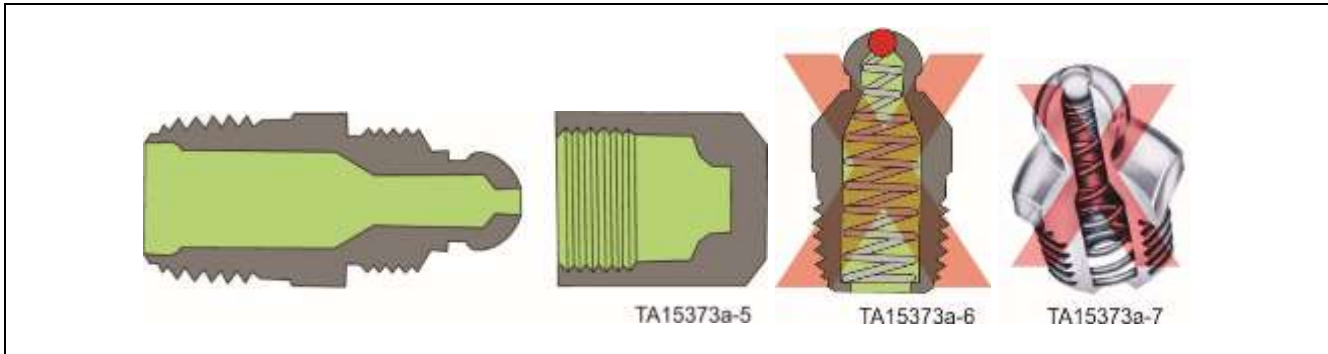
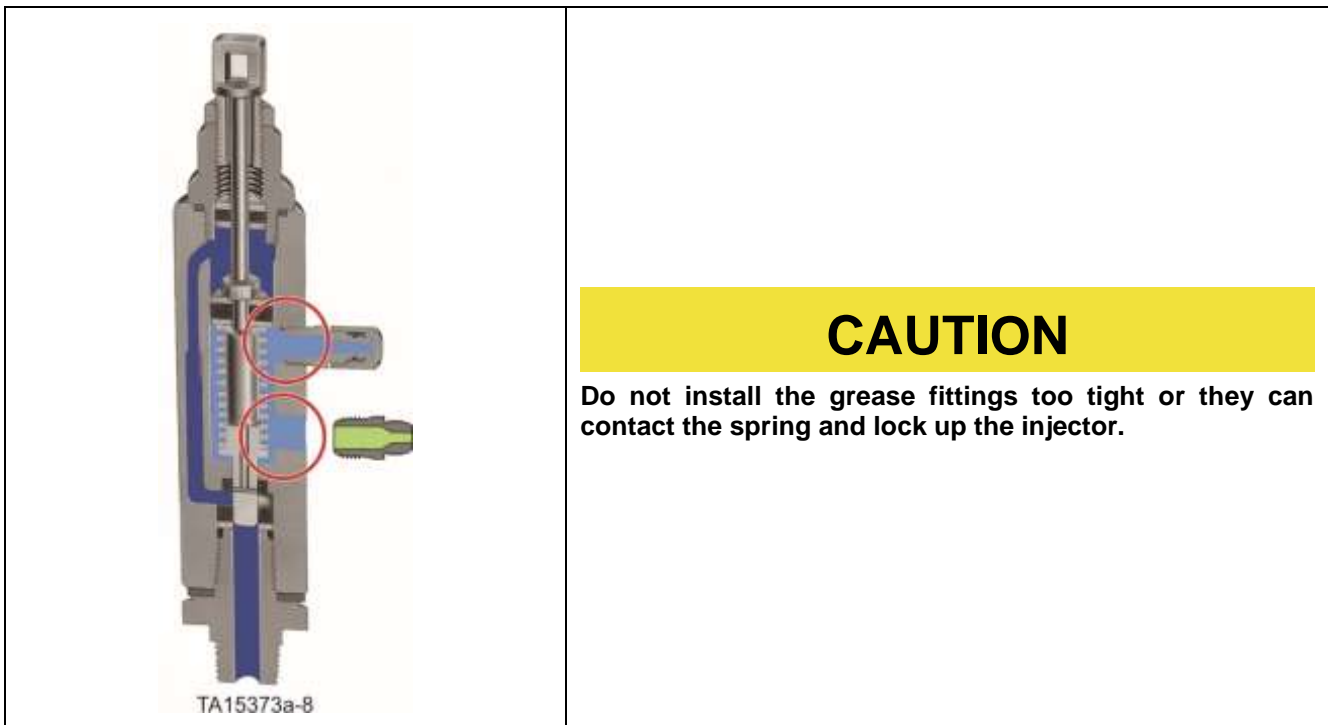


Figure 43. Grease purge fitting



CAUTION

Do not install the grease fittings too tight or they can contact the spring and lock up the injector.

Figure 44. Grease fitting interference

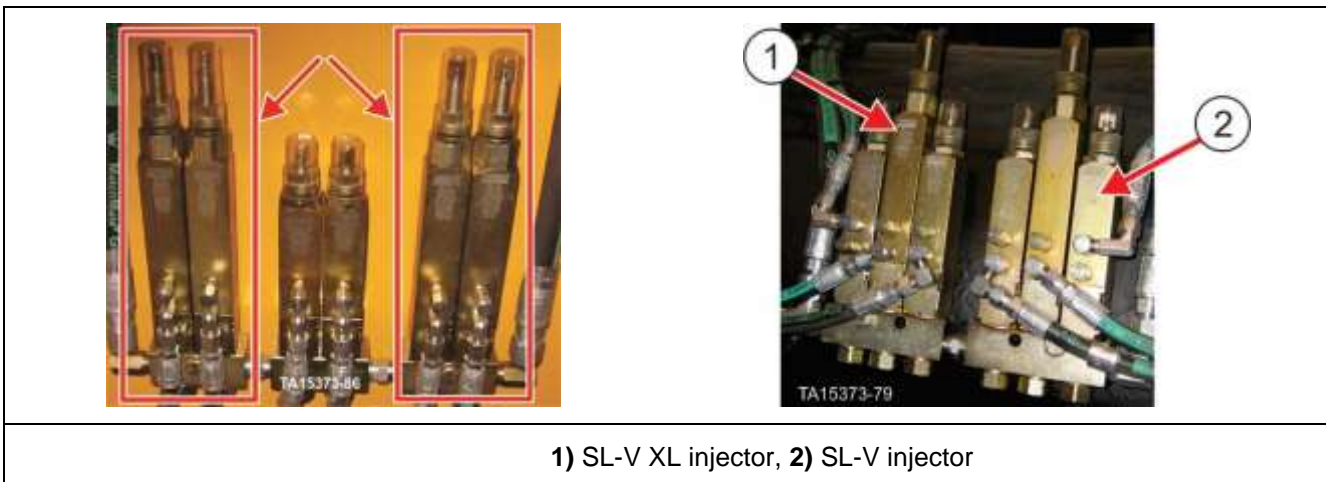
XL Injectors

On early production machines, the 9" inch articulation, 12" inch and 14" inch joints require dual injectors in order to supply sufficient grease. The SL-1 injector will be connected in parallel as shown below.



Figure 45. Dual injectors

In current production machines, XL injectors are used to provide more grease to a joint. A single SL-V XL high output injector set to maximum has 3.8 times the volume of either the SL-1 or SL-V injectors. A single SL-V XL can replace both dual or triple parallel injectors on early production machines.



1) SL-V XL injector, 2) SL-V injector

Figure 46. XL injectors

Verify that the critical joints have XL injectors. The joints with XL injectors are typically: *(this is a generic list verify this information for your specific machine)*

- a. The level link to bell crank injectors located on bellcrank.
- b. Verify that the hoses are connected correctly to the level link.
- c. The joint connected to the bellcrank should have an XL injector.
- d. The joint connected to the bucket will have a single injector.
- e. Lift arm ball cap injectors located in front frame.
- f. Hoist ball cap injectors located in front frame.
- g. Articulation joint upper and lower.
- h. Bucket pivot pin left and right.

Verify this on the Auto Lube diagram for your particular machine.

Adjust Grease Injectors

Safety Preparations

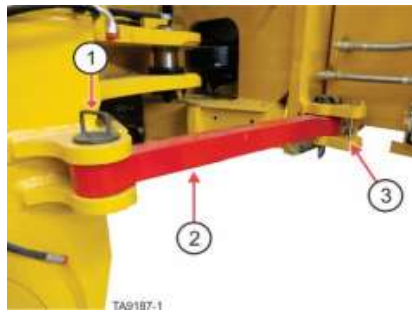
WARNING

Crush hazards exist if the machine is started or moved while work processes are being performed on the machine. Place bucket flat and level on the ground. Place frame lock in the locked position and lock out the machine's starting capability before performing any work process. Follow all applicable lockout procedures and local rules and regulations for performing work processes. ANYONE performing inspections or service procedures to the machine should be familiar with ALL instructions and procedures contained in the machine's SERVICE MANUAL. Crush hazard could occur if the machine is started or moves while any type of work process is being conducted on the machine, resulting in serious injury or death.

- a. Stop the wheel loader on flat level ground.
- b. Set bucket flat and level on the ground.
- c. Move the frame lock to the locked position so that the frame cannot be steered.

WARNING

Crush hazards exist in machine pivot area and area between the tires. Do not enter these areas unless it is verified that the operator has control over the steering and that personnel locking the frame lock have good communication with the operator. Entering the pivot area and area between the tires while the machine is moving or pivoting (articulating) could cause crush hazards resulting in serious injury or death.



- 1) Retaining pin for locked position, 2) Frame lock - shown in locked position,
- 3) Retaining pin bracket for un-locked position

Frame lock in locked position

- d. Place wheel chocks in front and behind each wheel.
- e. Set the parking brakes.
- f. Shut off the engine.

⚠ WARNING

Crush, shock, or other hazards exist if stored energy is not removed or isolated prior to working on the machine. Stored energy (hydraulic, electrical, pneumatic, mechanical, etc.) may be present if not isolated or released prior to working on the machine. Do not work on the machine without removing this stored energy (suspended loads, electrical power, air pressure, etc.). Risk of crushing, shock, or other physical injury exists if stored energy is not removed or isolated prior to working on the machine which could result in serious injury or death.

- g. Turn the battery and engine isolation switches to the off position and install locks on the battery isolation switch.



Figure 47. Battery Isolation Box – Battery isolation switch in OFF position with locks in place

- h. Release the air from the hydraulic reservoir by using the hydraulic reservoir air valve (ball valve) on top of the reservoir. The supply line from main air system will be blocked and reservoir air will vent out the hose that runs down the outside of the hydraulic reservoir.
- Turn the handle to the up position as shown

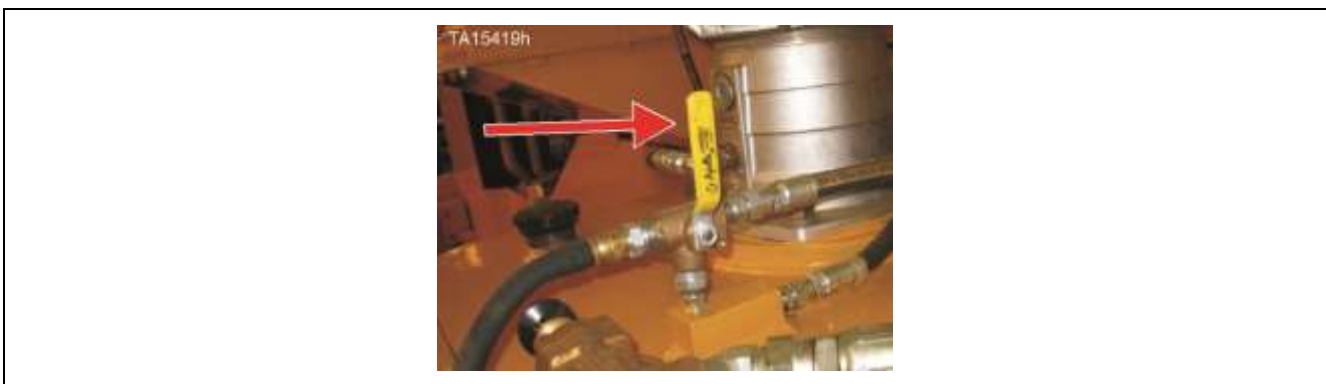


Figure 48. Hydraulic reservoir air valve handle UP

- i. Release the air from the various air storage reservoirs by opening all of the air bleed valves.
- Some machines do not have a remote drain valve for the KLENZ reservoir. They have only a manual valve on the bottom of the reservoir that must be manually released.

Three valves on right side of rear frame under hydraulic reservoir

One valve on right side of front frame near hoist cylinder ball cap



Open air reservoir bleed valves

WARNING

Crush hazards exist if all personnel are not cleared from the bucket and lift arm area before using the hydraulic hoist and bucket hydraulic pressure bleed down valves to relieve pressure from the hoist and bucket circuit. Assembly must be used only when the engine is NOT running. Before using the Manual Bleed Valve Assembly, refer to “HYDRAULIC AND GREASE SYSTEMS”, “MANUAL BLEED VALVE ASSEMBLY”, in Section 04 of the Service Manual for additional operational and safety information. Operating the manual bleed valve may cause the lift arms and bucket to descend rapidly. All personnel around the bucket and lift arms area shall be removed from the area before operating hydraulic hoist and bucket hydraulic pressure bleed down valves. Using the hydraulic bleed down valves could result in movement of the lift arms and bucket which could cause a crush hazard resulting serious injury or death.

- j. Use the hydraulic pressure bleed down valves located in the front frame underneath the Husco valves to bleed any stored pressure in the hoist and bucket cylinders.
- k. Turn each valve slowly counterclockwise as shown below and allow the pressure to bleed down.
 - Open the valve completely and leave it open during this procedure.



Figure 49. Pressure bleed down valves

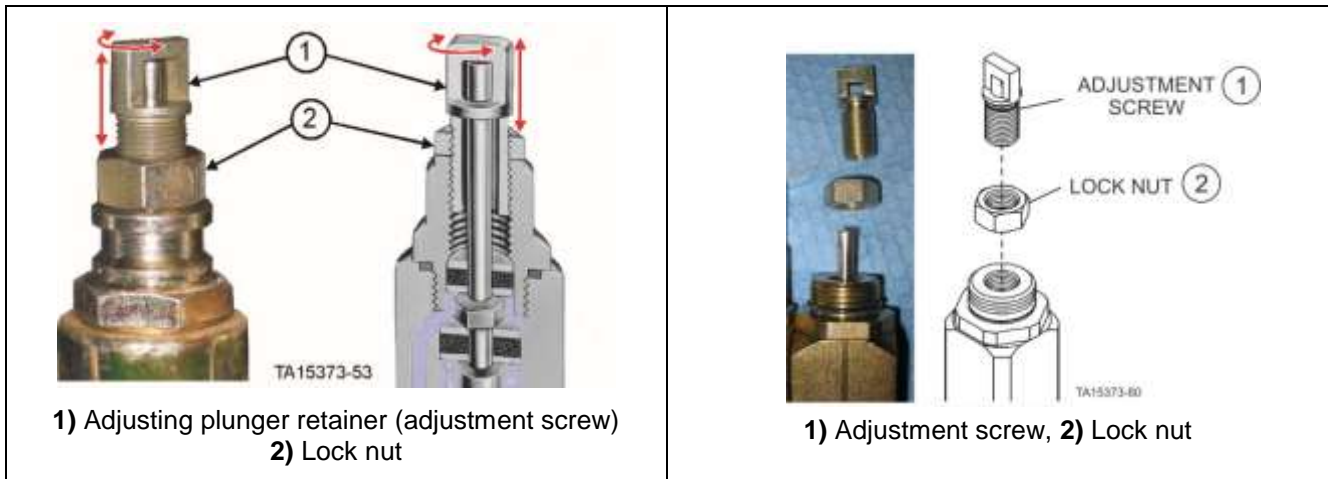


Figure 50. Adjust injector

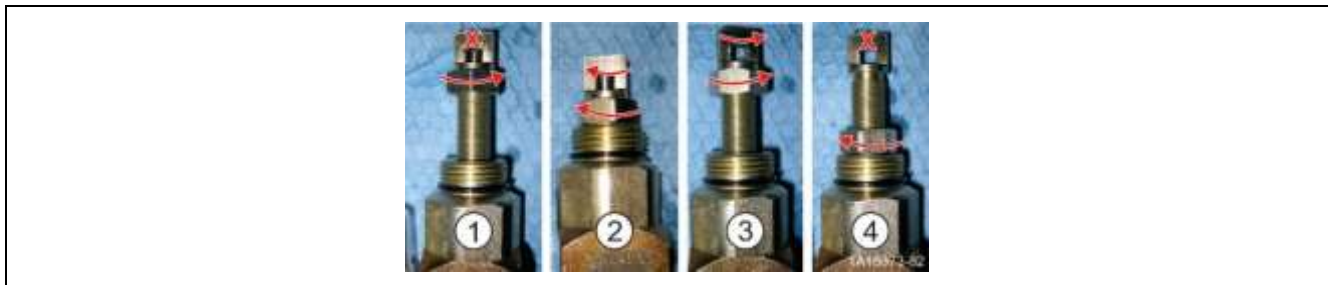


Figure 51. Adjust SL-V XL grease injectors

- l. Turn lock nut against the shoulder on the adjustment screw.
- m. Tighten the adjustment screw completely till it bottoms out on the lock nut.
- n. Turn the adjustment screw out:
 - **SL-V:** 5 turns for the maximum setting. (2-1/2 turns would be 50% output)
 - **SL-V XL:** 20.5 turns for the maximum setting. (10 turns would be 50% output)
- o. Hold the adjustment screw stationary and tighten the lock nut.

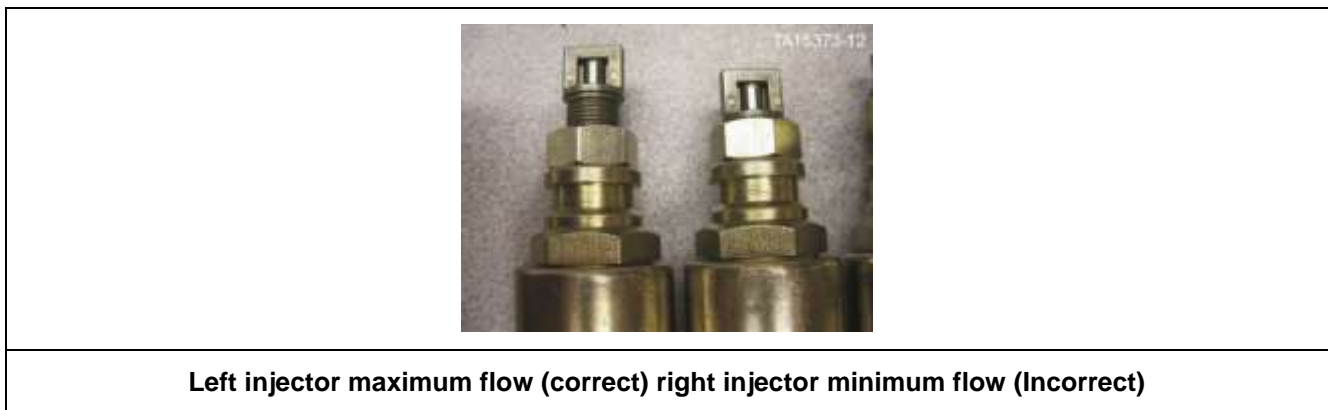


Figure 52. Injector flow

An alternative method is to use the Go-No-Go tool to measure the distance.



 <p>SL-V adjusted correctly for maximum output</p>	
<p>A) The top of the measurement, B) The bottom of the measurement</p>	<p>1) Adjusted too long, 2) Adjusted too short</p>

Figure 53. Adjust SL-V injector



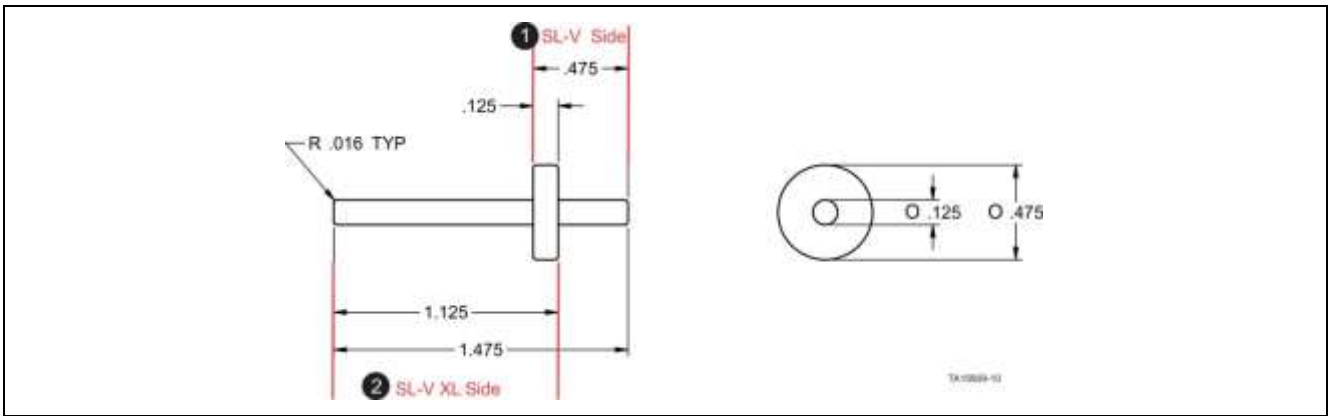
 <p>SL-V XL adjusted correctly for maximum output</p>	
<p>A) The top of the measurement, B) The bottom of the measurement</p>	<p>1) Adjusted too long, 2) Adjusted too short</p>

Figure 54. Adjust SL-V XL injector



1) SL-V Side, 2) SL-V XL Side (P/N R4279085)

Figure 55. Go-No-Go grease injector adjustment gauge

Check Each Grease Injector for Correct Operation

Using the attached injector checklist (in the appendix of this document), verify the proper adjustment of all the installed injectors on the machine.

- a. Remove the plastic cap from each injector.



Figure 56. Remove plastic cap (SL-1)

- b. With the pump in stall condition, verify that the measuring plunger rod on each injector has moved fully out of the inspection window.



Figure 57. Injector in rest position (SL-1)



Figure 58. Injector position with auto lube grease pump stalled (SL-1)

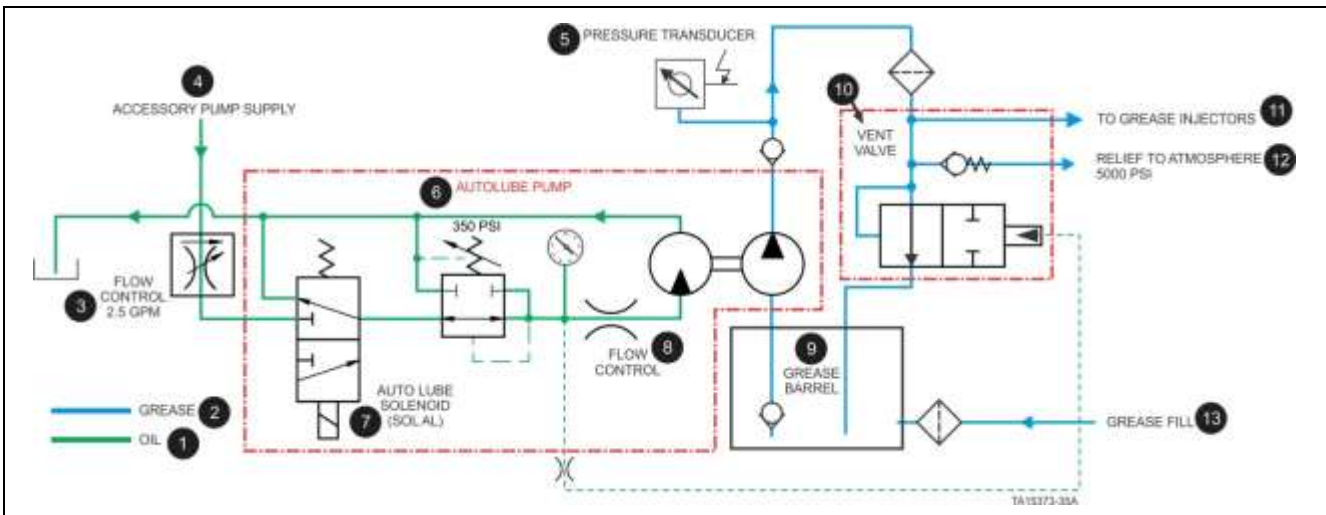
- c. If the measuring plunger rod has not moved fully out of the window with the pump stalled, then a problem may exist in either the injector, lubrication point and or the output connection hose.
- d. Replace the plastic cap on each injector. Failure to replace the cap may allow contamination to enter the injector and cause the injector to malfunction.



Figure 59. Install the plastic caps to protect the injectors from contamination

Vent Valve Operation

The vent valve is located in parallel between the grease pump outlet filter and the main grease supply lines to the grease injectors. This vent valve is hydraulically pilot controlled.



- | | |
|---|--|
| <ul style="list-style-type: none"> 1. Oil 2. Grease 3. Flow control 2.5 gpm 4. Accessory pump supply 5. Pressure transducer 6. Auto lube pump 7. Auto lube solenoid (SOL AL) | <ul style="list-style-type: none"> 8. Flow control 9. Grease barrel 10. Vent valve 11. To grease injectors 12. Relief to atmosphere 5000 psi 13. Grease fill |
|---|--|

Figure 60. Typical auto lube circuit

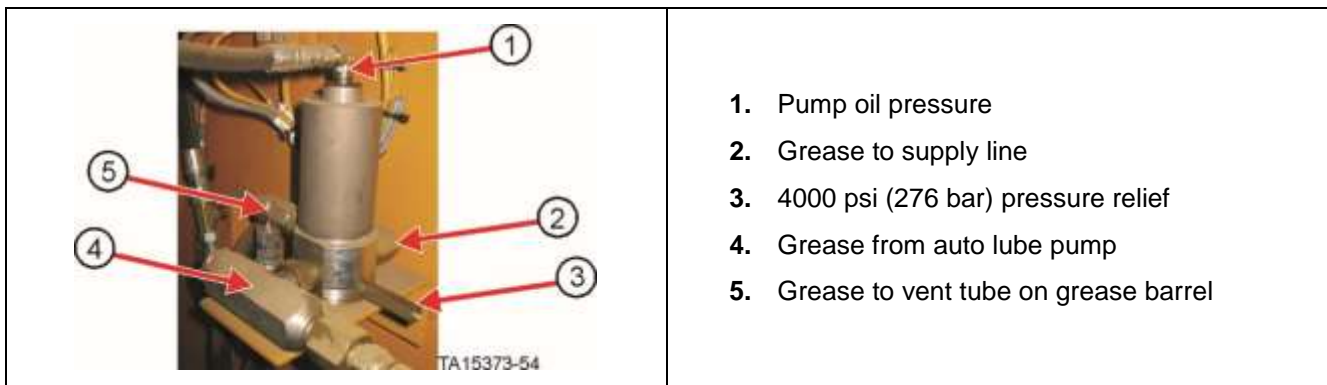


Figure 61. Auto lube vent valve

The vent valve has five (5) connection ports, four (4) of the ports have grease functions, and the remaining port is for the hydraulic pilot oil.

Grease ports:

- Three (3) of the grease ports are connected together to form a manifold. Two (2) of the three (3) grease ports are large $\frac{3}{4}$ " NPTF (grease supply in and out). Grease coming from the auto lube pump enters into the vent valve and then exists to the supply lines for the grease injectors.
- The grease pressure relief of 4000 psi (276 bar) is mounted in the third grease port ($\frac{1}{8}$ " NPTF) in the manifold.
- The other port with a grease function is a $\frac{1}{4}$ " NPTF port that directs the vented grease back to the grease reservoir at the end of the auto lube cycle. This return port has a needle control valve between the grease supply manifold and the return port.
- The last port on the top of the valve is for the hydraulic pilot control of the valve.

The vent valve is a pilot operated logic element.

- The valve is normally open with pilot oil required to close it.
- Pilot oil is supplied to the vent valve when the Auto Lube solenoid, located on the Auto Lube pump manifold, is energized.

- Oil flow through the Auto Lube pump manifold is through the:
 - Solenoid valve
 - Pressure relief valve
 - Oil galley between pressure relief valve and flow control
 - Oil galley to passage to vent valve orifice fitting (this orifice will control the rate at which the vent valve will open and close.)
 - Orifice fitting to the vent valve pilot oil port

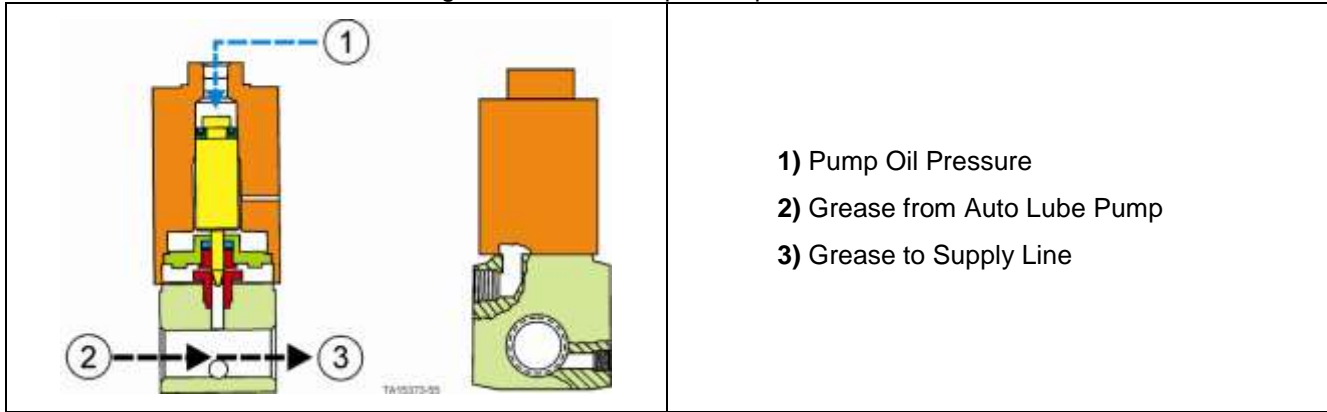


Figure 62. Vent valve in the pressurized and closed position grease supplied to the system

As the auto lube pump begins to operate, pilot oil flows to the top of the vent valve.

- This oil applies pressure to a hydraulic piston inside the vent valve. As the piston moves, it contacts the needle valve assembly.
- The needle valve is pressed down hard onto a seat area. This blocks the grease manifold from the return port.
- The grease will then pass through the vent valve and flows out to the various injector banks through the grease supply lines.
- A check valve on the outlet of the grease pump prevents grease supply line pressure from back pressuring the grease pump. Because of this check valve, grease supply pressure is retained in the supply lines after the pump cycle is completed.

When the grease pump lube cycle is completed, the retained grease pressure in the supply lines must be reduced. This reduction of supply line pressure is accomplished by the vent valve.

- When the grease pump is shut off, the pilot oil on the top of the vent valve piston is vented back to the hydraulic reservoir.
- As the vent valve pilot oil pressure drops, the injector supply grease pressure pushes against the needle valve.
- The needle valve is unseated and the grease pressure in the grease supply lines is allowed to bleed back to the grease reservoir.
- As the grease supply line pressure drops below 600 psi (41.3 bar) for SL-1 injectors and 100 psi (68.9 bar) for SL-V and SL-V XL injectors, the injectors start to reload (stage 4).
- The vent valve will continue to stay in the open (vented) position until the start of the next grease cycle.

NOTICE

The residual grease pressure must drop below 600 psi (41.3 bar) for the SL-1 and 1000 psi (68.9 bar) for the SL-V and SL-V XL for the grease injector to properly cycle. Improper grease grade will result in the residual grease pressure remaining too high and the injectors will not cycle properly.

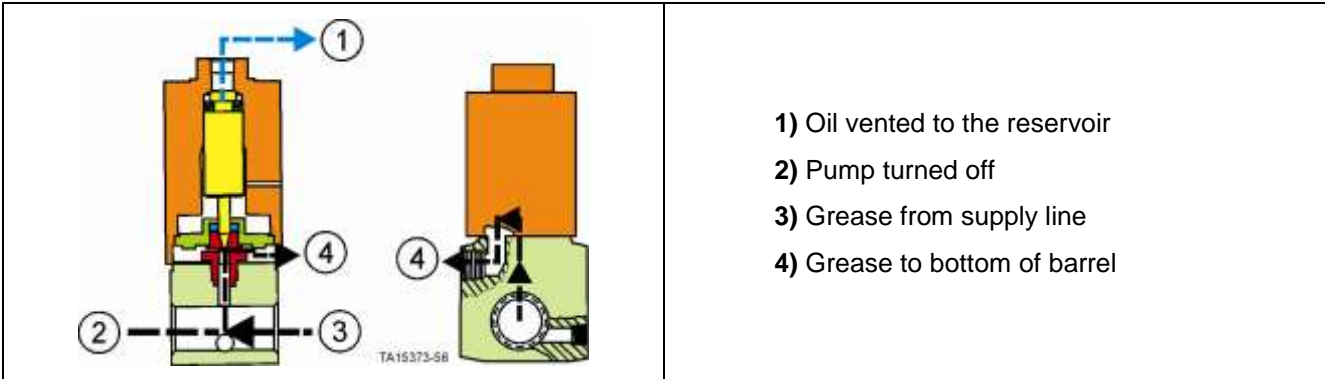


Figure 63. Vent valve in the open position grease is vented back to the bottom of the barrel

There is a small weep hole on the side of the vent valve. This hole will be dry under normal operation and should remain unobstructed.

- If oil comes from this hole the piston oil seal is blown
- If grease comes from this hole the grease seal is blown

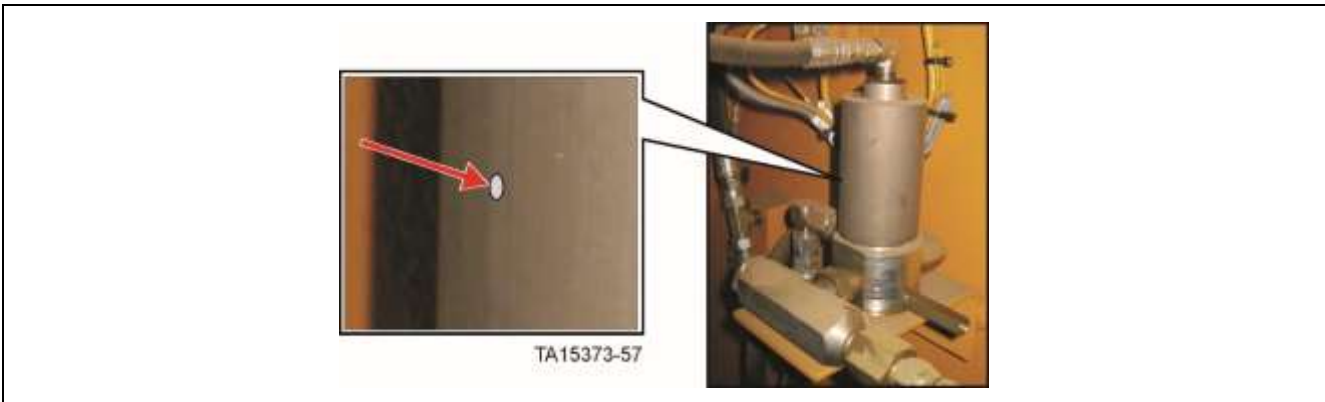


Figure 64. Vent valve weep hole

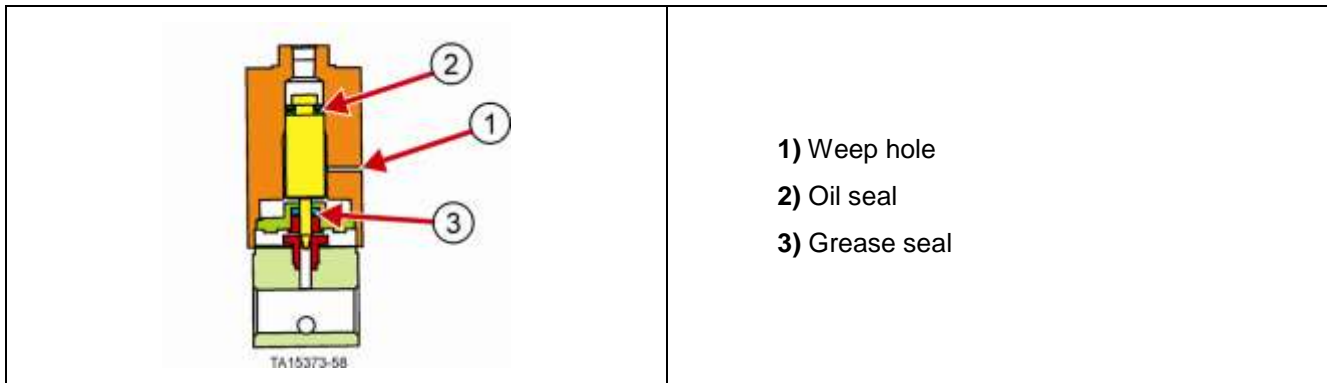


Figure 65. Vent valve weep hole

The brass fitting in the VENT port of the Auto Lube Pump control manifold has a very small orifice. This controls how fast the vent valve closes and opens. This orifice must be in place for proper operation of the vent valve.

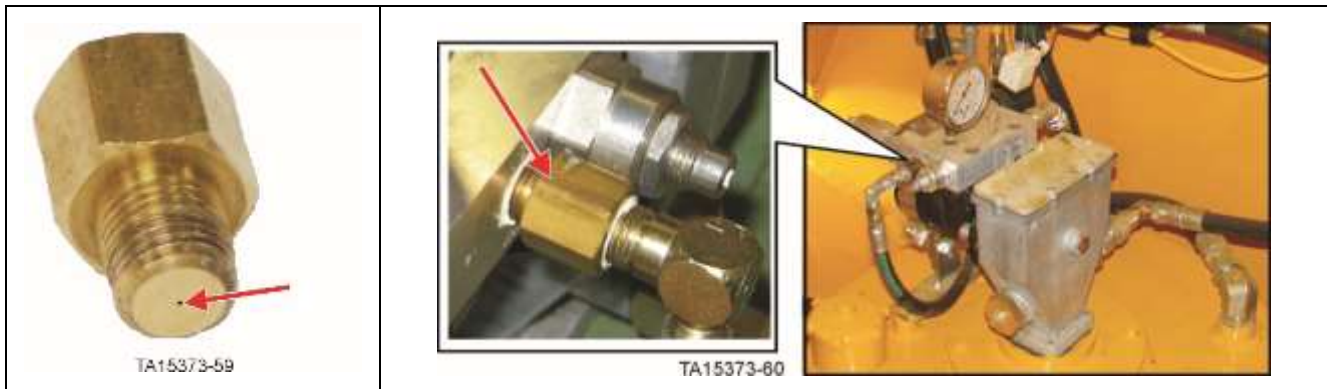


Figure 66. Vent valve orifice

If the vent valve is not functioning properly and no problem is found this orifice should be checked for contamination.

Quick check of vent valve function:

- Remove the hose between the vent valve and the first injector bank.
- Cap the outlet of the vent valve.
- Operate the pump and monitor the pump for hydraulic pressure and flow (you can hear the pump rotating).
 - If the pump stalls and does not rotate the vent valve is OK and the pump is OK.
 - If the pump continues to rotate or the pressure is low, stop the pump.
 - Move the cap to the pump outlet.
 - Restart the test and monitor the pressure and flow.
 - If the pump stalls and there is no flow then the vent valve was at fault.
 - If the pump continues to run then the pump is at fault.

In-Line Filters Maintenance

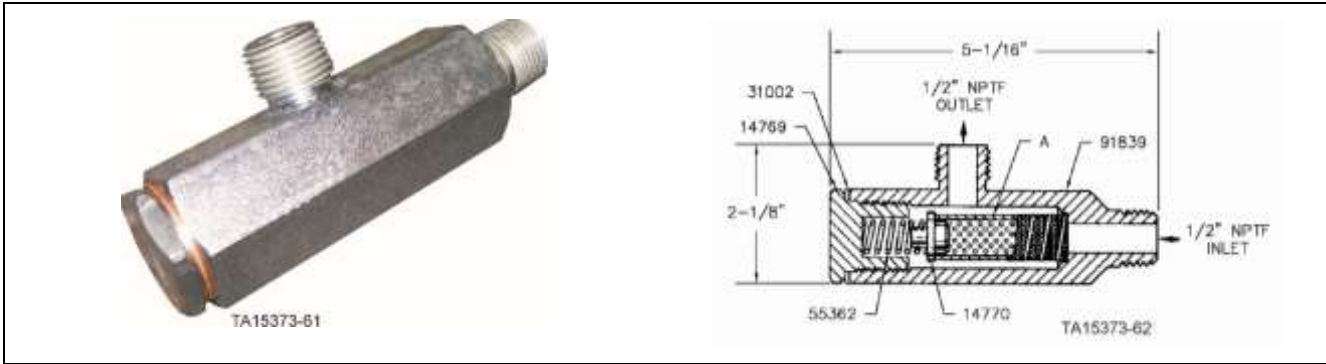


Figure 67. In line filter

There are two in-line filters in the automatic lubrication system.

- One filters the lubricant as it is delivered to the reservoir, from the ground level fitting used for filling the reservoir.

NOTICE

The inline filter for filling the reservoir may be located behind the auto lube reservoir and be hard to access. The inline filter may be moved to a more accessible location if desired.

- The other, filters the lubricant before it is delivered to the vent valve and the injectors.

Note the orientation of the inlet and outlet of the filter.

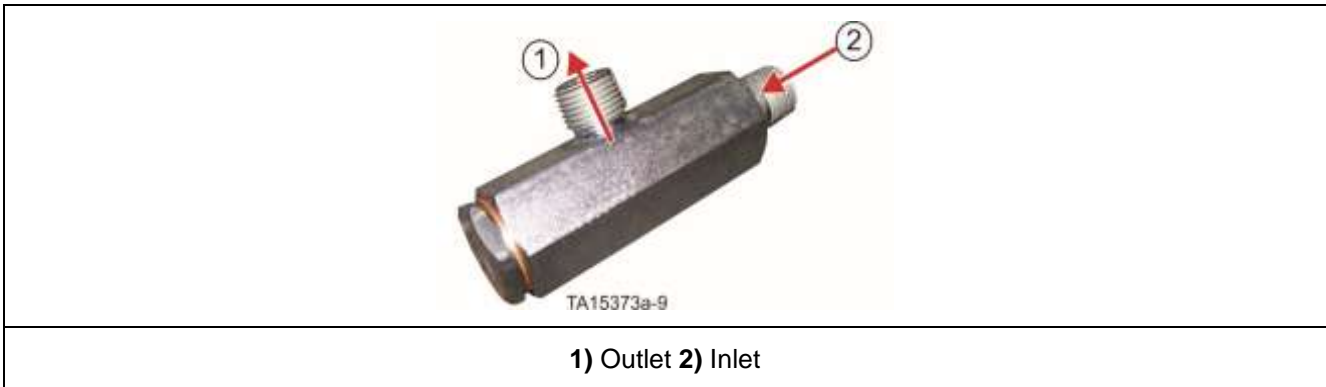


Figure 68. In line filter inlet and outlet

If the filter is plugged, an internal spring allows the filter element to move and allows the grease (and contamination) to bypass (enter the system).

CAUTION

A blocked filter element can disintegrate under pressure and damage an entire lubrication system. If the system develops higher than normal pressures, the filter element may be the cause. The filter should be checked for contamination and replaced if necessary.

The vendor recommendation is to remove and clean the filter elements every 500 hours. This interval may vary depending on local conditions. Clean the filter thoroughly with solvent or replace if necessary.

The replacement interval of the filter varies, depending on the application, contamination in the grease, type of grease, etc. Changing this filter and the hydraulic filters at the same time is suggested.



Figure 69. Filter cleaning

Grease Compatibility

Mixing of different greases is not advisable. The grease chemical composition becomes very important when switching from summer grease to winter grease or from one grade to another or from one brand to another brand. Incompatible grease may result in hardening of the grease and/or loss of the anti-wear components due to chemical reactions between the greases. Any time the grease type or brand is changed, a complete cleaning of the grease system should be performed. This includes:

- Grease reservoir (remove the reservoir and wash inside).
- Complete purge of all grease injector supply lines.
- Flush of the injectors to the pivot point. (This can be accomplished by attaching a hand operated grease pump to the grease fitting on each of the grease injectors and fully flushing the grease from the injector through the grease line and the pivot point).

The following chart is the most common types of grease thickeners or soap types available today. The grease manufacturer normally provides a specification sheet that lists the type of thickener or soap type along with other specific information. The following compatibility chart should be used as a general guide only.

On new machine assemblies, check with a Komatsu Product Representative to determine the type of grease supplied from the factory.

NOTICE

The following compatibility chart should be used only as a general guide, as different grease brand's specific properties may cause compatibility problems.

C = COMPATIBLE	Aluminum Complex	Barium Complex	Calcium Stearate	Calcium 12-Hydroxy	Calcium Complex	Calcium Sulfonate Complex	Bentonite Clay (Non-Soap)	Lithium Stearate	Lithium 12-Hydroxy	Lithium Complex	Polyurea (Conventional)	Polyurea Shear (Stable)												
													B = BORDERLINE (Check with grease vendor)											
													I = INCOMPATIBLE											
Aluminum Complex	C	I	I	C	I	B	I	I	I	B	I	C												
Barium Complex	I	C	I	C	I	C	I	I	I	I	I	B												
Calcium Stearate	I	I	C	C	I	C	C	C	B	C	I	C												
Calcium 12-Hydroxy	C	C	C	C	B	B	C	C	C	C	I	C												
Calcium Complex	I	I	I	B	C	I	I	I	I	C	C	C												
Calcium Sulfonate Complex	B	C	C	B	I	C	I	B	B	C	I	C												
Bentonite Clay (Non-Soap)	I	I	C	C	I	I	C	I	I	I	I	B												
Lithium Stearate	I	I	C	C	I	B	I	C	C	C	I	C												
Lithium 12-Hydroxy	I	I	B	C	I	B	I	C	C	C	I	C												
Lithium Complex	B	I	C	C	C	C	I	C	C	C	I	C												
Polyurea (Conventional)	I	I	I	I	C	I	I	I	I	I	C	C												
Polyurea (Shear Stable)	C	B	C	C	C	C	B	C	C	C	C	C												

Filling the Grease Reservoir

Safety Preparations

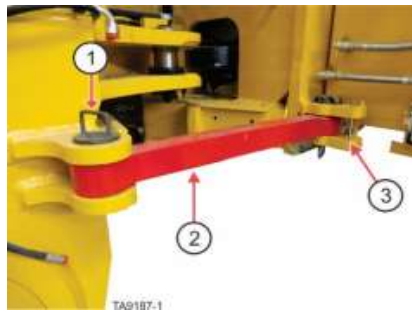
WARNING

Crush hazards exist if the machine is started or moved while work processes are being performed on the machine. Place bucket flat and level on the ground. Place frame lock in the locked position and lock out the machine's starting capability before performing any work process. Follow all applicable lockout procedures and local rules and regulations for performing work processes. ANYONE performing inspections or service procedures to the machine should be familiar with ALL instructions and procedures contained in the machine's SERVICE MANUAL. Crush hazard could occur if the machine is started or moves while any type of work process is being conducted on the machine, resulting in serious injury or death.

- a. Stop the wheel loader on flat level ground.
- b. Set bucket flat and level on the ground.
- c. Move the frame lock to the locked position so that the frame cannot be steered.

WARNING

Crush hazards exist in machine pivot area and area between the tires. Do not enter these areas unless it is verified that the operator has control over the steering and that personnel locking the frame lock have good communication with the operator. Entering the pivot area and area between the tires while the machine is moving or pivoting (articulating) could cause crush hazards resulting in serious injury or death.



- 1) Retaining pin for locked position, 2) Frame lock - shown in locked position,
- 3) Retaining pin bracket for un-locked position

Frame lock in locked position

- d. Place wheel chocks in front and behind each wheel.
- e. Set the parking brakes.
- f. Shut off the engine.

⚠ WARNING

Crush, shock, or other hazards exist if stored energy is not removed or isolated prior to working on the machine. Stored energy (hydraulic, electrical, pneumatic, mechanical, etc.) may be present if not isolated or released prior to working on the machine. Do not work on the machine without removing this stored energy (suspended loads, electrical power, air pressure, etc.). Risk of crushing, shock, or other physical injury exists if stored energy is not removed or isolated prior to working on the machine which could result in serious injury or death.

- g. Turn the battery and engine isolation switches to the off position and install locks on the battery isolation switch.



Figure 70. Battery Isolation Box – Battery isolation switch in OFF position with locks in place

⚠ WARNING

Crush hazards exist if all personnel are not cleared from the bucket and lift arm area before using the hydraulic hoist and bucket hydraulic pressure bleed down valves to relieve pressure from the hoist and bucket circuit. Assembly must be used only when the engine is NOT running. Before using the Manual Bleed Valve Assembly, refer to “HYDRAULIC AND GREASE SYSTEMS”, “MANUAL BLEED VALVE ASSEMBLY”, in Section 04 of the Service Manual for additional operational and safety information. Operating the manual bleed valve may cause the lift arms and bucket to descend rapidly. All personnel around the bucket and lift arms area shall be removed from the area before operating hydraulic hoist and bucket hydraulic pressure bleed down valves. Using the hydraulic bleed down valves could result in movement of the lift arms and bucket which could cause a crush hazard resulting serious injury or death.

Fill the reservoir by using the following procedure:

- h. Attach grease hose from lubricant truck to the fill fitting located on the front frame, at the pivot area, on the left side of the machine (refer to illustration below).
 - This fitting (1) is accessible from the ground.
- i. Remove the protective cap from the overflow tube.
 - Ensure the overflow tube is not plugged.
- j. Fill reservoir until fresh grease exits the overflow tube (2).
- k. Replace the protective cap on the overflow tube.



- 1) Filler fitting
- 2) Overflow tube

Figure 71. Grease reservoir filler fitting

- I. Follow all lockout tag out rules, local rules, and local regulations to return the machine back to service.

CAUTION

Clean filler hose grease fitting before connecting filler hose.

CAUTION

It is necessary to prime the system after replacing or emptying the grease reservoir.

Priming the System and Using the Manual Lubrication Functions

The loader has three switches (and a hydraulic bypass) by which to use the Automatic Lubrication System pump to prime the lines and injectors.

The Automatic Lubrication pump is hydraulically powered. These switches are operable only when the engine is running.

- The MANUAL LUBE SWITCH is located in the operator's cab.
- The LUBRICATION CYCLE SWITCH is mounted in the front frame of machine. (above grease reservoir)
- Another LUBRICATION CYCLE SWITCH is mounted inside the "ISOLATION & CONTROL SWITCH BOX ASSEMBLY", mounted on the left side of the rear frame.





Figure 72. Lubrication switch locations

A manual solenoid bypass is also provided on the auto lube pump assembly. While the engine is running, perform the following to place the pump in bypass or normal operation.

- To manually open the solenoid, pull the red knob and turn $\frac{1}{4}$ turn left or right.
- The pump should operate continuously while in bypass operation.
- To place the solenoid in normal operation, turn the knob until it snaps back into locked position.
- The pump should operate normally when commanded.

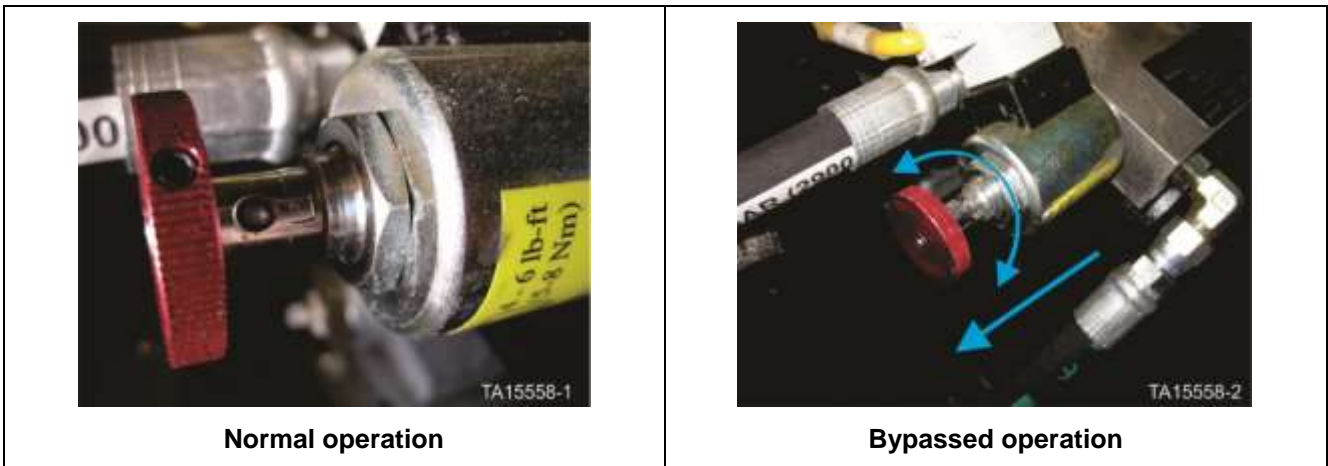


Figure 73. Manual auto lube pump solenoid bypass

Supply Lines: After the grease reservoir has been filled with lubricant, remove all plugs in dead ends of the injector manifolds and supply lines. Turn vent plug, in pump, counterclockwise one complete turn. Operate pump until lubricant flows freely from vent plug opening to expel air pockets trapped between the pump and the supply line connection. Tighten vent plug. Continue operating pump until all plug openings are closed and supply lines are primed.

NOTICE

The layout diagrams for items 3 and 4 are typical and representative of many machines. However, any specific items should be verified on the schematics and layouts for your machine.

Auto Lube Pump Setup Check List

Item	Action	Completed?
1	Check oil level in auto lube pump gearbox	Yes <input type="checkbox"/> No <input type="checkbox"/>
2	Check the oil pressure. It should be in the range of 300-350 psi (20.7 24 bar) (with motor stalled) (not adjustable on current production machines). If the pressure is not within the range, the pressure regulating valve will need to be replaced.	Pressure _____
3	Check the grease pressure. It should be in the range of 3000-4000 psi (275.8 bar) (with motor stalled) (not adjustable on current production machines)	Yes <input type="checkbox"/> No <input type="checkbox"/> N/A <input type="checkbox"/>
4	Close flow control and open to 1/4 turn open. (not adjustable on current production machines)	Yes <input type="checkbox"/> No <input type="checkbox"/> N/A <input type="checkbox"/>
5	Verify pump time is 60 - 75 seconds (adjust flow control if needed) (not adjustable on current production machines) If the time is not within the range, the flow control valve will need to be replaced.	Time _____

Fluid Specifications

Auto Lube Grease Specifications

**Type of Grease	**Minimum Ambient Temperature	**Grease Grade
Pumpable auto lube grease fortified with extremely high pressure and anti-wear properties for slow speed, high shock application The grease is required to have minimum 3% to maximum 5% MoS ₂ "Molybdenum Disulfide" additive.	+70°F (+20°C) and above	NLGI #2 grease
	+50°F (+10°C) and above	NLGI #1 grease
	+10°F (-12°C) to 50°F (+10°C),	NLGI #0 grease
	-30°F (-34°C) to +10°F (-12°C)	NLGI #00 grease

CAUTION

** The values listed for grade and temperature in the table GREASE SPECIFICATIONS are only general guidelines for grease grade. Grease specifications can vary widely, depending on the location where the grease was blended and local conditions. Each grease meeting the 3-5% Molybdenum Disulfide requirement should also have the Lincoln Ventmeter number verified to make sure it meets system requirements. Use of incorrect grease that does not meet the Ventmeter specification may cause pump problems and the injectors may not cycle and refill properly.

Depending on the characteristics of the grease it is possible that a thicker NLGI grade of grease may be used at lower temperatures than shown in the table GREASE SPECIFICATIONS as long as the grease meets the Lincoln Ventmeter specifications.

NOTICE

LINCOLN VENTMETER SPECIFICATION

At a temperature that is 10°F (5°C) below the minimum ambient temperature to which the machine will be exposed, the Lincoln Ventmeter reading should be:

Injector Type	Ventmeter Reading
SL-1 injectors	500 psi (34.5 bar) or less
SL-V and SL-V XL injectors	900 psi (62.0 bar) or less

For Example:

- The minimum mine temperature is 0°F (-17.8°C).

Mine site temperature	Minus	10°F (5°C)	Equals	Target Temperature
0°F (-17.8°C)	minus	10°F (5°C)	=	-10°F (-23.3°C)

Examples:

Grease/Grade	Ventmeter Reading	Target Temperature	Acceptability
Brand XYZ	900 psi (62 bar)	15°F (-9.4°C)	Unacceptable
Brand ABC	400 psi (27.6 bar)	-10°F (-23.3°C)	Acceptable

The Lincoln Ventmeter test is typically performed by Lincoln and/or the grease manufacturer, by using a Ventmeter tool as shown.



Auto Lube Pump Fluid Specifications

Lincoln Automatic Lubrication Pump	15 oz.	444 ml.	10W30 motor oil
------------------------------------	--------	---------	-----------------

Minimum Grease Interval and Volume Requirements for the Spherical Ball Joints

Ball Size	Grease injector volume per cycle	# of SL-1 or SL-V injectors (set to maximum)	Time interval (maximum)
7.5" 9"	.080 cu in (.131 cc)	1	15 minutes or less
12" 14"	.160 cu in (.262 cc)	2 (a single SL-V XL may also be used)	15 minutes or less

Figure 74. The minimum grease interval, and volume requirements for the spherical ball joints

Auto Lube Grease Injector Check Sheet Loader

(This check list is for a typical auto lube system and may not be correct for all loaders. If there are any discrepancies refer to the auto lube diagrams that came with your machine.)

Loader Grease Injector Check List			
Location of injector	Description	Adjusted Correctly	Operating Correctly
Lift Arms			
Right Bell Crank	Level Link to Bucket Joint		
	Level Link to Bell Crank Joint (double injectors tied with hard tube between the injectors)		
	Bell Crank to Bucket Cylinder		
	RHS Inside Bell Crank Joint		
	LHS Outside Bell Crank Joint		
Left Bell Crank	Level Link to Bucket Joint		
	Level Link to Bell Crank Joint (double injectors tied with hard tube between the injectors)		
	Bell Crank to Bucket Cylinder		
	RHS Inside Bell Crank Joint		
	LHS Outside Bell Crank Joint		
Right Torque Tube	Bell Crank Pivot Ear		
	RH Bucket Pivot Boss (double injectors tied with hard tube between the injectors) <i>(L-950 is single injector at this location.)</i>		
	RH Hoist Ear Pivot		
Left Torque Tube	Bell Crank Pivot Ear		
	LH Bucket Pivot Boss (double injectors tied with hard tube between the injectors) <i>(L-950 is single injector at this location.)</i>		
	LH Hoist Ear Pivot		
Front Frame			
RHS Upper Torque Tube	RH Lift Arm Socket Pivot (double injectors tied with hard tube between the injectors)		
	RH Bucket Cylinder Pivot		
LHS Upper Torque Tube	LH Lift Arm Socket Pivot (double injectors tied with hard tube between the injectors)		
	LH Bucket Cylinder Pivot		
Front Frame Wall	LH Hoist Cylinder Ball Joint (double injectors tied with hard tube between the injectors)		
	RH Hoist Cylinder Ball Joint (double injectors tied with hard tube between the injectors)		
	Upper Articulation Ball Joint (double injectors tied with hard tube between the injectors)		
	Lower Articulation Ball Joint (double injectors tied with hard tube between the injectors)		
	LH Steering Cylinder Pin		
	RH Steering Cylinder Pin		
Rear Frame			
Left Hand Wall	RH Steering Cylinder Pivot		
	LH Steering Cylinder Pivot		
	Rear Axle Articulation Socket Front		
	Rear Axle Articulation Socket Rear		
(RHS = Right Hand Side) (LHS = Left Hand Side) (RH = Right Hand) (LH = Left Hand)			

Auto Lube Grease Injector Check Sheet Dozer

(This check list is for a typical auto lube system and may not be correct for all dozers. If there are any discrepancies refer to the auto lube diagrams that came with your machine.)

Dozer Grease Injector Check List			
Location	Description	Adjusted Correctly	Operating Correctly
Push Beam and Cylinders			
RH Push Beam	RH Pitch Cylinder to Blade Pivot		
	RH Push Beam to Push Plate Pivot		
	RH Push Beam to Blade Pivot		
	RH Push Beam to Hoist Cylinder Pivot		
LH Push Beam	LH Pitch Cylinder to Blade Pivot		
	LH Push Beam to Push Plate Pivot		
	LH Push Beam to Blade Pivot		
	LH Push Beam to Hoist Cylinder Pivot		
RH Push Plate	RH Pitch Cylinder to Push Plate Pivot		
	RHS Push Plate		
	RHS Push Plate		
	RHS Push Plate		
LH Push Plate	LH Pitch Cylinder to Push Plate Pivot		
	LHS Push Plate		
	LHS Push Plate		
	LHS Push Plate		
Front Frame			
RH Top Front Frame	RH Outside Hoist Cylinder Pivot		
	RH Inside Hoist Cylinder Pivot		
	RH Hoist Cylinder Pivot		
	RH Tilt Cylinder Pivot		
LH Top Front Frame	LH Outside Hoist Cylinder Pivot		
	LH Inside Hoist Cylinder Pivot		
	LH Hoist Cylinder Pivot		
	LH Tilt Cylinder Pivot		
Front Frame Wall	RH Front Axle Push Plate Pivot		
	LH Front Axle Push Plate Pivot		
	Upper Articulation Ball Joint (double injectors tied with hard tube between the injectors)		
	Lower Articulation Ball Joint (double injectors tied with hard tube between the injectors)		
	LH Steering Cylinder Pin		
	RH Steering Cylinder Pin		
Rear Frame			
Left Hand Wall	RH Steering Cylinder Pivot		
	LH Steering Cylinder Pivot		
	Rear Axle Articulation Socket Front		
	Rear Axle Articulation Socket Rear		
(RHS = Right Hand Side) (LHS = Left Hand Side) (RH = Right Hand) (LH = Left Hand)			